



Turbine water meter

- Hermetically sealed register (IP68)
- Display on 7 drums (5 for m³, 3 for litres)
- Magnetic protection
- DN50 - DN100
- Register maybe rotated through 360°
- Optional pulse, M-bus, Radio frequency output
- GG25 Cast iron housing
- Powder coating ensures maximum corrosion protection
- Low head loss
- Water temperature up to 30°C

Technical Specifications

Nominal diameter	DN	mm	50	65	80	100
Nominal flow rate	Q ₃	m ³ /h	25	40	63	100
Maksimum flow rate	Q ₄	m ³ /h	31,250	50	78,750	125
Minimum flow rate	Q ₁	l/h	0,3125	0,50	0,7875	1,250
Transitional flow rate	Q ₂	l/h	0,500	0,800	1,260	2
Maximum working pressure	P _{max}	bar	16	16	16	16
Pressure loss (max.Q3)	ΔP	bar	0,25	0,25	0,25	0,25
Maximum working temperature	T _{max}	°C	30	30	30	30
Measuring range	Q ₃ /Q ₁	R	80	80	80	80
Overall lenght	l	mm	200	200	225	250
Maximum register indication		m ³	9.999.999	9.999.999	9.999.999	9.999.999
Verification scale interval		l	0,001	0,001	0,001	0,001
Height	H	mm	175	175	175	175
Height of centerline	h	mm	82	90	100	110
Nominal installation diameter	DN	mm	50	65	80	100
Weight	-	kg	8,5	10,5	14,5	19

Dimensions

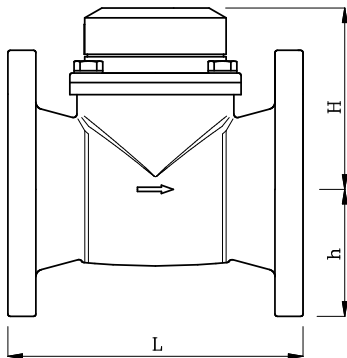

WS-DN50

WS-DN65

WS-DN80

WS-DN100

Error Curve

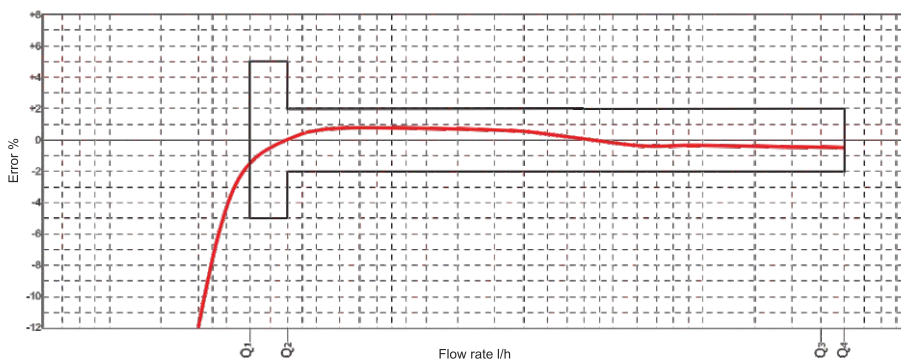

Pressure Loss

