



## **WATERFLUX 3070** Handbook

Battery powered electromagnetic water meter with optional KROHNE FlexPower

Electronic Revision 5.1.0\_  
(SW.REV.5.1.0\_)

All rights reserved. It is prohibited to reproduce this documentation, or any part thereof, without the prior written authorisation of KROHNE Messtechnik GmbH.

Subject to change without notice.

Copyright 2022 by  
KROHNE Messtechnik GmbH - Ludwig-Krohne-Str. 5 - 47058 Duisburg (Germany)

<b>1</b>	<b>Safety instructions</b>	<b>6</b>
1.1	Software history .....	6
1.2	Intended use .....	7
1.3	Certification .....	7
1.4	Safety instructions from the manufacturer .....	8
1.4.1	Copyright and data protection .....	8
1.4.2	Disclaimer .....	8
1.4.3	Product liability and warranty .....	9
1.4.4	Information concerning the documentation .....	9
1.4.5	Warnings and symbols used .....	10
1.5	Safety instructions for the operator .....	10
1.6	Instruction for transportation and handling of batteries .....	11
<b>2</b>	<b>Device description</b>	<b>12</b>
2.1	Scope of delivery .....	12
2.2	Device description .....	13
2.3	Nameplate (example) .....	14
<b>3</b>	<b>Installation</b>	<b>15</b>
3.1	General notes on installation .....	15
3.2	Storage .....	15
3.3	Transport .....	15
3.4	Pre-installation requirements .....	16
3.5	General requirements .....	16
3.5.1	Vibration .....	16
3.5.2	Magnetic field .....	16
3.6	Installation conditions .....	17
3.6.1	Inlet and outlet .....	17
3.6.2	T-section .....	17
3.6.3	Open feed or discharge .....	17
3.6.4	Bends .....	18
3.6.5	Pump .....	19
3.6.6	Control valve .....	19
3.6.7	Air venting and vacuum forces .....	20
3.6.8	Flange Deviation .....	21
3.6.9	Mounting position .....	21
3.6.10	Installation in a metering pit and subsurface applications .....	22
3.7	Mounting .....	23
3.7.1	Torques and pressures .....	23
3.8	Mounting of the signal converter .....	26
3.8.1	Remote signal converter housing .....	26
3.8.2	Closing of the signal converter housing .....	26
3.8.3	Mounting of the KROHNE FlexPower unit .....	27

4	Electrical connections	28
4.1	Safety instructions	28
4.2	Important notes on electrical connection	28
4.3	Grounding	29
4.4	Cable overview	30
4.5	Connection of the flow sensor cable	31
4.6	Connection of the signal cable	32
4.6.1	IP68 housing (compact version)	32
4.6.2	IP68 housing (remote version)	33
5	Start-up	35
5.1	Connecting the internal battery	35
5.2	Connecting the external battery	36
5.2.1	IP68 housing (compact and remote version)	36
5.3	Power supply - battery	36
5.4	Power supply - KROHNE FlexPower	36
5.4.1	Connection of the FlexPower unit	37
5.5	Starting the signal converter	38
6	Operation	39
6.1	Display and operating elements	39
6.1.1	Show counters and flow rate on the display	40
6.1.2	Show software version, diameter, meter constant and display test on the display	41
6.1.3	Status information on the display	42
6.2	Access control	42
6.2.1	Access levels to the menu	43
6.2.2	Access to the service menu only	43
6.2.3	Meters subject to metrology	44
6.2.4	Metrological seals	44
6.2.5	Utility seals	45
6.2.6	Reset full access to the menu	46
6.3	Menu	47
6.3.1	View or change menu settings	47
6.3.2	Menu overview	48
6.3.3	Access control	51
6.3.4	Automatic Meter Reading mode (AMR)	51
6.3.5	Counters and flow rate	52
6.3.6	Pulse output	54
6.3.7	Status output	57
6.3.8	Pressure and temperature settings	58
6.3.9	Measurement settings	60
6.3.10	Meter configuration settings	61
6.3.11	Service and test settings	61
6.3.12	Battery settings	62
6.3.13	Modbus settings	63
6.4	Tests	64
6.4.1	Automatic self-test	64
6.4.2	Verification mode	64
6.4.3	Test mode	64

7 Service	65
7.1 Types of batteries	65
7.1.1 Replacement of internal battery	66
7.1.2 Replacement of external battery	67
7.2 Replacement of the KROHNE FlexPower unit	68
7.3 Spare parts availability	69
7.4 Availability of services	69
7.5 Returning the device to the manufacturer	69
7.5.1 General information	69
7.5.2 Form (for copying) to accompany a returned device	70
7.6 Disposal	70
8 Technical data	71
8.1 Measuring principle	71
8.2 Technical data	72
8.3 Integrated P&T sensor (optional)	79
8.4 KROHNE FlexPower (optional)	80
8.5 Modbus protocol (option)	81
8.6 Legal metrology	82
8.6.1 OIML R49	82
8.6.2 MID Annex III (MI-001)	85
8.6.3 Verification to MID Annex III (MI-001) and OIML R49	87
8.7 Measurement accuracy	88
8.7.1 WATERFLUX 3070 without straight inlet and outlet sections	89
8.8 Dimensions and weights	90
8.9 Pressure loss	93
8.10 Battery lifetime	94
9 Notes	95

## 1.1 Software history

The "Electronic Revision" (ER) is consulted to document the revision status of electronic equipment according to NE 53 for all GDC devices. It is easy to see from the ER whether troubleshooting or larger changes in the electronic equipment have taken place and how that has affected the compatibility.

### Changes and effect on compatibility

1	Downwards compatible changes and fault repair with no effect on operation (e.g. spelling mistakes on display)
3- _	Downwards compatible hardware and/or software change of inputs and outputs:
	P Pulse output
	S Status output
X	All inputs and outputs
4	Downwards compatible changes with new functions
5	Incompatible changes, i.e. electronic equipment must be changed.

Release date	Electronic revision *	Changes and compatibility	CCRC code	Documentation
2016	ER 5.0.1_ (SW. REV. 5.0.1_)	Initial software version	0X4Cb5	MA WATERFLUX 3070 V3-R01
2016	ER 5.0.2_ (SW. REV. 5.0.2_)	1	0X71d5	MA WATERFLUX 3070 V3-R01
2017	ER 5.0.3_ (SW. REV. 5.0.3_)	1	0XCFF7	not issued
2018	ER 5.0.4_ (SW. REV. 5.0.3_)	1	0XCFF7	not issued
2018	ER 5.0.5_ (SW. REV. 5.0.5_)	4	0X0CAB	not issued
2019	ER 5.0.5_ (SW. REV. 5.0.5_)			MA WATERFLUX 3070 V3-R02
2022	ER 5.1.0_ (SW. REV. 5.1.0_)	5	0XAB62	MA WATERFLUX 3070 V3-R03

\* See the KROHNE website, for earlier software versions used in previous versions of the WATERFLUX 3070.

## 1.2 Intended use

**WARNING!**

*If the device is not used according to the operating conditions (refer to chapter Technical data), the intended protection could be affected.*

**CAUTION!**

*Responsibility for the use of the measuring devices with regard to suitability, intended use and corrosion resistance of the used materials against the measured fluid lies solely with the operator.*

**INFORMATION!**

*The manufacturer is not liable for any damage resulting from improper use or use for other than the intended purpose.*

This flowmeter is designed exclusively to measure the flow of drinking water and raw water.

## 1.3 Certification

### Product marking



Figure 1-1: Examples of marking logo

The manufacturer certifies successful testing of the product by applying the conformity mark on the device.

### **This device fulfils the statutory requirements of the relevant directives.**

For more information on the directives, standards and the approved certifications, please refer to the declaration of conformity supplied with the device or downloadable from the manufacturer's website.

### **Other approvals and standards**

- Measuring Instruments Directive 2014/32/EU, Annex III (MI-001) / and UK Measuring Instrument Regulation 2016 No. 1153.

For more information, please refer to the dedicated documentation.

## 1.4 Safety instructions from the manufacturer

### 1.4.1 Copyright and data protection

The contents of this document have been created with great care. Nevertheless, we provide no guarantee that the contents are correct, complete or up-to-date.

The contents and works in this document are subject to copyright. Contributions from third parties are identified as such. Reproduction, processing, dissemination and any type of use beyond what is permitted under copyright requires written authorisation from the respective author and/or the manufacturer.

The manufacturer tries always to observe the copyrights of others, and to draw on works created in-house or works in the public domain.

The collection of personal data (such as names, street addresses or e-mail addresses) in the manufacturer's documents is always on a voluntary basis whenever possible. Whenever feasible, it is always possible to make use of the offerings and services without providing any personal data.

We draw your attention to the fact that data transmission over the Internet (e.g. when communicating by e-mail) may involve gaps in security. It is not possible to protect such data completely against access by third parties.

We hereby expressly prohibit the use of the contact data published as part of our duty to publish an imprint for the purpose of sending us any advertising or informational materials that we have not expressly requested.

### 1.4.2 Disclaimer

The manufacturer will not be liable for any damage of any kind by using its product, including, but not limited to direct, indirect or incidental and consequential damages.

This disclaimer does not apply in case the manufacturer has acted on purpose or with gross negligence. In the event any applicable law does not allow such limitations on implied warranties or the exclusion of limitation of certain damages, you may, if such law applies to you, not be subject to some or all of the above disclaimer, exclusions or limitations.

Any product purchased from the manufacturer is warranted in accordance with the relevant product documentation and our Terms and Conditions of Sale.

The manufacturer reserves the right to alter the content of its documents, including this disclaimer in any way, at any time, for any reason, without prior notification, and will not be liable in any way for possible consequences of such changes.



### 1.4.3 Product liability and warranty

The operator shall bear responsibility for the suitability of the device for the specific purpose. The manufacturer accepts no liability for the consequences of misuse by the operator. Improper installation or operation of the devices (systems) will cause the warranty to be void. The respective "Standard Terms and Conditions" which form the basis for the sales contract shall also apply.

### 1.4.4 Information concerning the documentation

To prevent any injury to the user or damage to the device it is essential that you read the information in this document and observe applicable national standards, safety requirements and accident prevention regulations.

If this document is not in your native language and if you have any problems understanding the text, we advise you to contact your local office for assistance. The manufacturer cannot accept responsibility for any damage or injury caused by misunderstanding of the information in this document.

This document is provided to help you establish operating conditions, which will permit safe and efficient use of this device. Special considerations and precautions are also described in the document, which appear in the form of icons as shown below.

### 1.4.5 Warnings and symbols used

Safety warnings are indicated by the following symbols.



**DANGER!**

*This information refers to the immediate danger when working with electricity.*



**DANGER!**

*This warning refers to the immediate danger of burns caused by heat or hot surfaces.*



**DANGER!**

*These warnings must be observed without fail. Even partial disregard of this warning can lead to serious health problems and even death. There is also the risk of seriously damaging the device or parts of the operator's plant.*



**WARNING!**

*Disregarding this safety warning, even if only in part, poses the risk of serious health problems. There is also the risk of damaging the device or parts of the operator's plant.*



**CAUTION!**

*Disregarding these instructions can result in damage to the device or to parts of the operator's plant.*



**INFORMATION!**

*These instructions contain important information for the handling of the device.*



**LEGAL NOTICE!**

*This note contains information on statutory directives and standards.*



• **HANDLING**

This symbol designates all instructions for actions to be carried out by the operator in the specified sequence.

➔ **RESULT**

This symbol refers to all important consequences of the previous actions.

## 1.5 Safety instructions for the operator



**WARNING!**

*In general, devices from the manufacturer may only be installed, commissioned, operated and maintained by properly trained and authorized personnel.*

*This document is provided to help you establish operating conditions, which will permit safe and efficient use of this device.*

## 1.6 Instruction for transportation and handling of batteries

**WARNING!**

*Lithium batteries are primary power sources with high energy content. If mistreated, they may present a potential risk.*

**INFORMATION!**

*The lithium batteries supplied, are **non-rechargeable**. Do NOT recharge the empty lithium batteries. Dispose of them according to the local legislation in your country.*

**INFORMATION!**

*The manufacturer assumes no liability for customer failure.*

**Please observe the following instructions:**

- Transport only in special packaging with special labels and transportation documents.
- Do not short-circuit, recharge, overcharge or connect with false polarity.
- Do not expose to temperature beyond the specified temperature range or incinerate the battery.
- Do not crush, puncture or open cells or disassemble battery packs.
- Do not weld or solder to the body of the battery.
- Do not expose contents of battery to water.
- Remove the battery from device before returning to the manufacturer for service or warranty reasons.
- Dispose battery packs in accordance with local regulations; where possible, recycle used batteries.

## 2.1 Scope of delivery



**INFORMATION!**

Do a check of the packing list to make sure that you have all the elements given in the order.



**INFORMATION!**

Inspect the packaging carefully for damages or signs of rough handling. Report damage to the carrier and to the local office of the manufacturer.



**INFORMATION!**

The remote version will arrive in two cartons. One carton contains the signal converter and one carton contains the flow sensor.

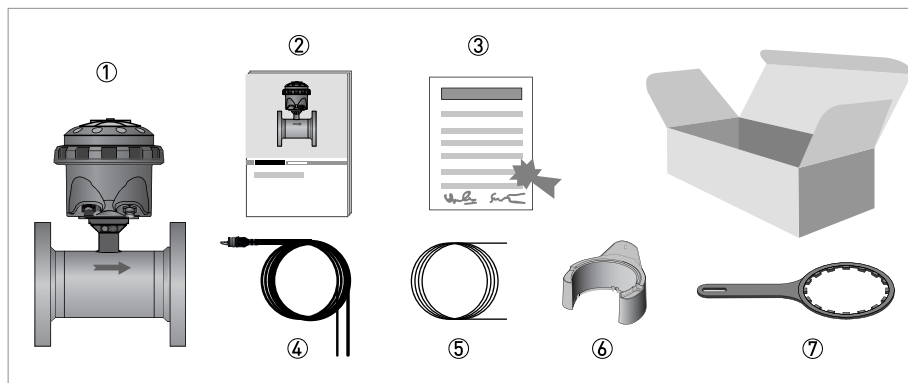

Figure 2-1: Scope of delivery

- ① Ordered water meter (compact or remote version)
- ② Product documentation
- ③ Factory calibration report
- ④ Combined signal/power cable (delivered according order)
- ⑤ Sensor cable (remote version)
- ⑥ Wall holder (remote version)
- ⑦ Special wrench for loosening the locking ring of the cover



**INFORMATION!**

Assembly materials and tools are not part of the delivery. Use the assembly materials and tools in compliance with the applicable occupational health and safety directives.



**INFORMATION!**

Special cable and/or cable assemblies are delivered according to the ordered signal converter type.



**INFORMATION!**

The signal converter housing is delivered with attached IP67 dust caps to protect the connections of the signal converter. After removing the caps and connecting the signal- and sensor cables, the signal converter housing and connections are IP68 rated.

## 2.2 Device description

Your measuring device is supplied ready for operation. The factory settings for the operating data have been made in accordance with your order specifications.



### **INFORMATION!**

Product specific information and extensive product specification is available using PICK, the Product Information Center KROHNE web-tool.



PICK can be found via the service menu button on the KROHNE.com website.

### The following versions are available:

- Compact version (the signal converter is mounted directly on the measuring sensor) in polycarbonate (IP68) housing
- Remote version (measuring sensor with a stainless steel connection box and a signal converter) in a remote, polycarbonate housing

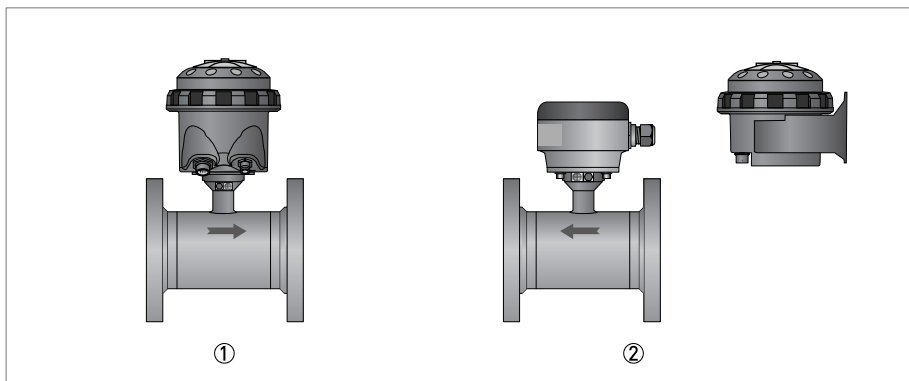

Figure 2-2: Device versions

- ① Compact version
- ② Remote version

Both versions are available with an optional integrated P&T sensor.

## 2.3 Nameplate (example)

**INFORMATION!**

Check the device nameplate to ensure that the device is delivered according to your order.

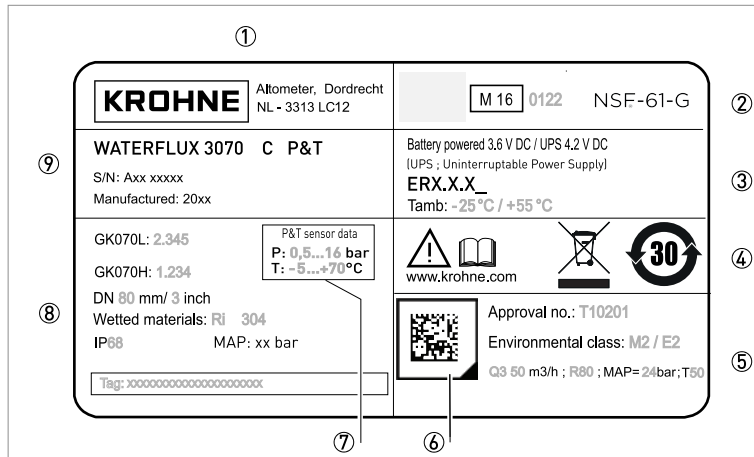

Figure 2-3: Example of nameplate

- ① Name and address of the manufacturer
- ② Comformity mark (e.g. CE/UKCA) with number(s) of notified body/bodies and additional certifications
- ③ Battery voltage UPS and Electronic Revision number
- ④ Disposal logo and supplier website
- ⑤ Optional (MI-001): Approval number, environmental info and metrology data
- ⑥ Data matrix
- ⑦ Specific pressure and temperature data
- ⑧ Meter constant, diameter, wetted materials, protection class
- ⑨ Type designation of the flowmeter, serial number, date of manufacturing  
[option: text P&T only for versions with integrated pressure and temperature sensor]

### 3.1 General notes on installation

**INFORMATION!**

Inspect the packaging carefully for damages or signs of rough handling. Report damage to the carrier and to the local office of the manufacturer.

**INFORMATION!**

Do a check of the packing list to make sure that you have all the elements given in the order.

**INFORMATION!**

Look at the device nameplate to ensure that the device is delivered according to your order. Check for the correct supply voltage printed on the nameplate.

### 3.2 Storage

- Store the device in a dry, dust-free location.
- Avoid continuous direct sunlight.
- Store the device in its original packaging.
- Storage temperature: -30...+70°C / -22...+158°F

### 3.3 Transport

**Signal converter**

- No special requirements.

**Compact version**

- Do not lift the device by the signal converter housing.
- Do not use lifting chains.
- To transport flange devices, use lifting straps. Wrap these around both process connections.

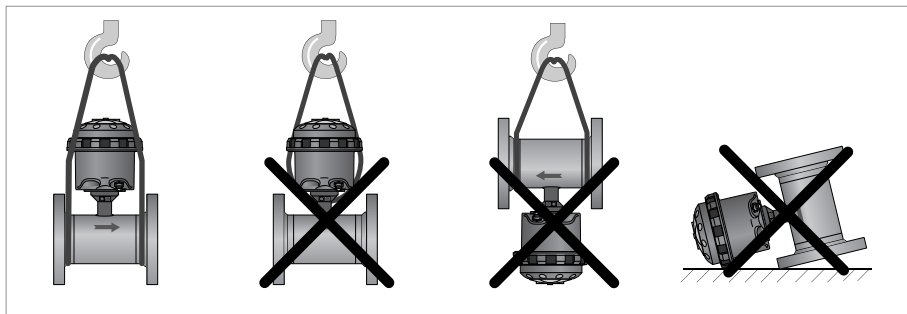

Figure 3-1: Transport

### 3.4 Pre-installation requirements

Make sure that you have all necessary tools available:

- Allen key (4 mm)
- Small screwdriver
- Wrench for cable glands (remote version only)
- Wrench for wall mounting bracket (remote version only)
- Torque wrench for installing flowmeter in pipeline

### 3.5 General requirements



#### **INFORMATION!**

The following precautions must be taken to ensure reliable installation.

- Make sure that there is adequate space to the sides.
- Protect the signal converter from direct sunlight and install a sun shade if necessary.
- Signal converters installed in control cabinets require adequate cooling, e.g. by fan or heat exchanger.
- Do not expose the signal converter to intense vibrations and mechanical shocks. The measuring devices are tested for a vibration/shock level as described in the chapter "Technical data".
- Avoid magnetic field! Keep at least 5 DN distance between electromagnetic flow sensors.

#### 3.5.1 Vibration

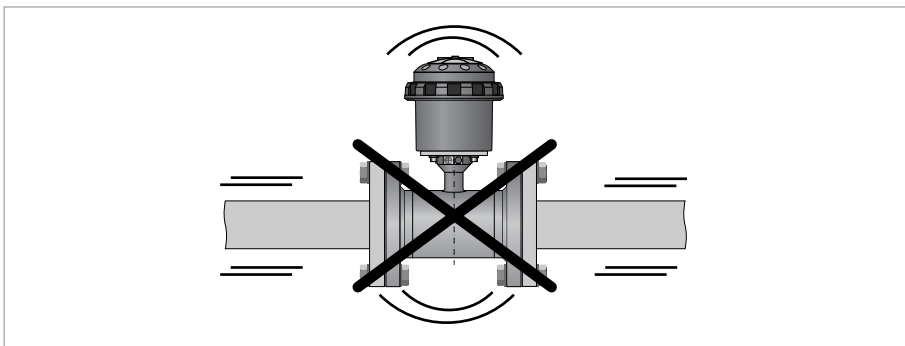

Figure 3-2: Avoid vibrations

#### 3.5.2 Magnetic field

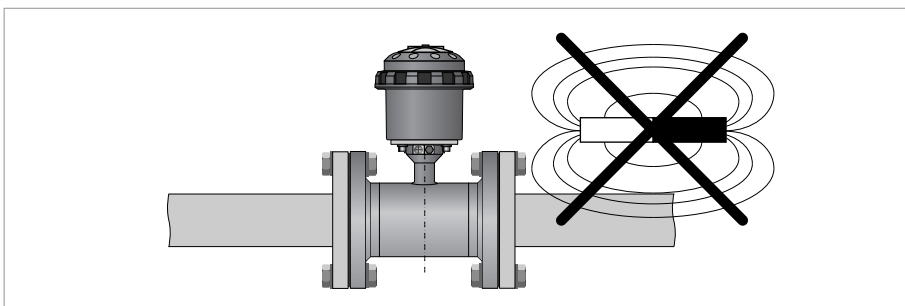

Figure 3-3: Avoid magnetic fields



### 3.6 Installation conditions



#### CAUTION!

To prevent damage to the Rilsan® coating, the WATERFLUX 3000 flow sensor must be installed carefully. Take precautions during transport and installation to protect the in- and outlet of the flow sensor.

#### 3.6.1 Inlet and outlet

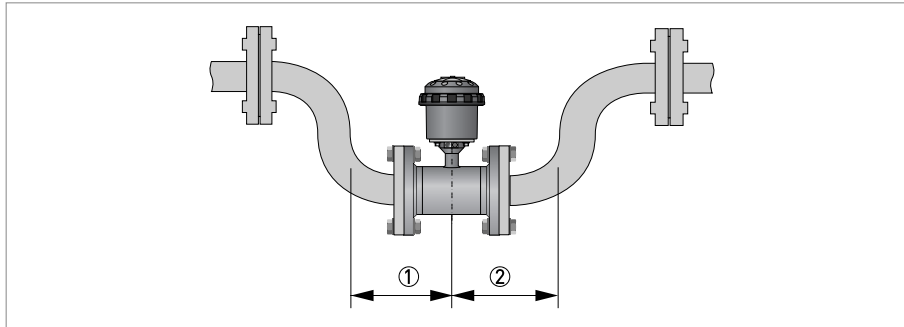

Figure 3-4: Minimal inlet and outlet

- ① Inlet:  $\geq 0$  DN
- ② Outlet:  $\geq 0$  DN

#### 3.6.2 T-section

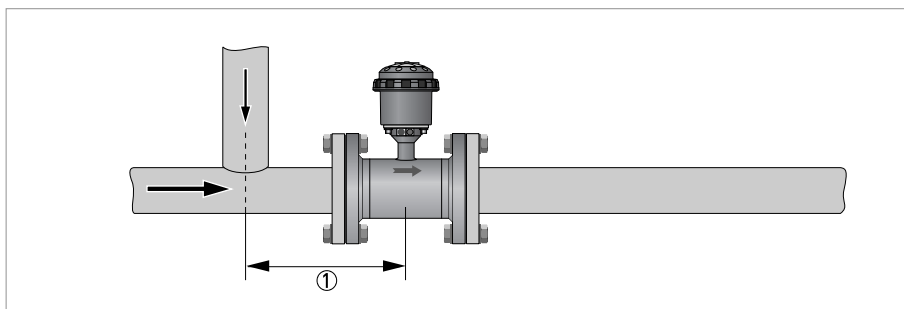

Figure 3-5: Distance behind a T-section

- ①  $\geq 0$  DN

#### 3.6.3 Open feed or discharge

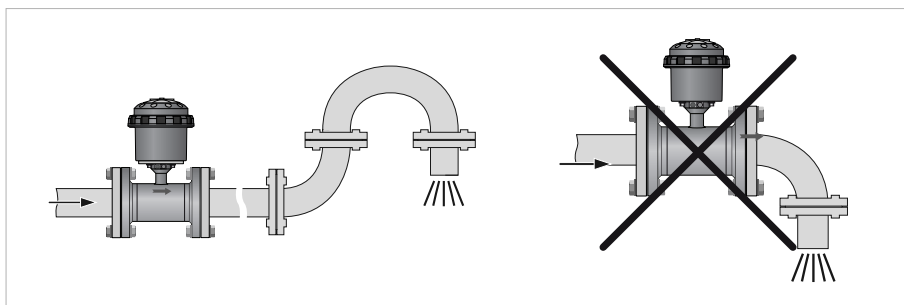

Figure 3-6: Installation in front of an open discharge

## 3.6.4 Bends

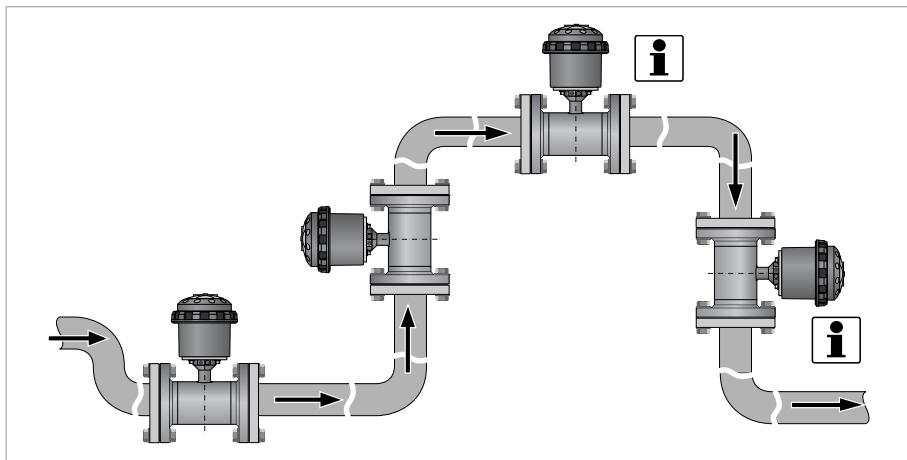

Figure 3-7: Installation in bending pipes (90°)

**INFORMATION!**

Recommended installation positions are at a lowered or ascending section of the pipeline installation. Installation at the highest point will enlarge the risk of flowmeter malfunction, because of air/gas bubbles.

Vertical installation in combination with an open discharge has to be avoided.

Vertical installation with a controlled back-pressure is possible.

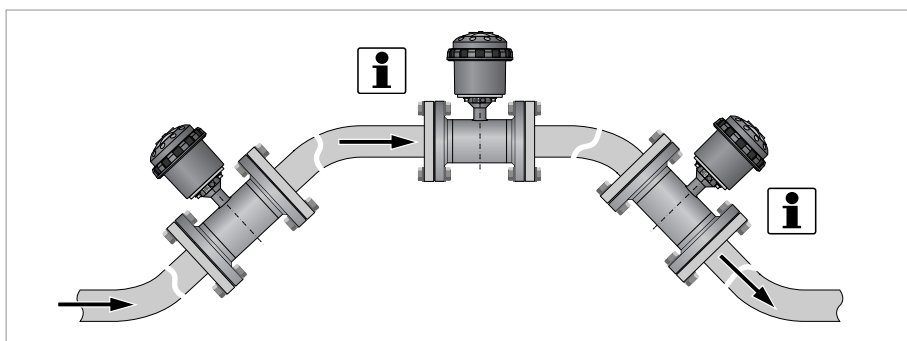

Figure 3-8: Installation in bending pipes (45°)

**CAUTION!**

Avoid draining or partial filling of the flow sensor.

**INFORMATION!**

Vertical installation on a descending slope in the pipeline is only recommended when the back-pressure is controlled.

### 3.6.5 Pump

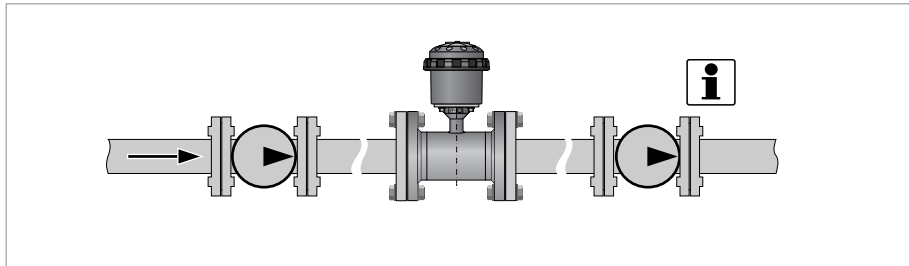

Figure 3-9: Recommended installation: behind a pump



#### **INFORMATION!**

Recommended position to install a flowmeter is downstream a pump (on a position where the flow disturbances of the pump are resolved).

An electromagnetic flowmeter can be installed in the suction line of a pump if there is no cavitation in the pipeline system.

### 3.6.6 Control valve

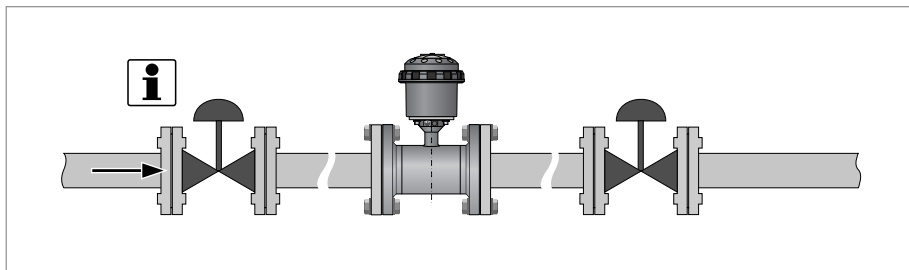

Figure 3-10: Recommended installation: in front of a control valve



#### **INFORMATION!**

Recommended position to install a flowmeter is upstream a control valve.

An electromagnetic flowmeter can be installed downstream of the control valve if there is no cavitation in the pipeline system (e.g. flow profile disturbances are resolved).

## 3.6.7 Air venting and vacuum forces

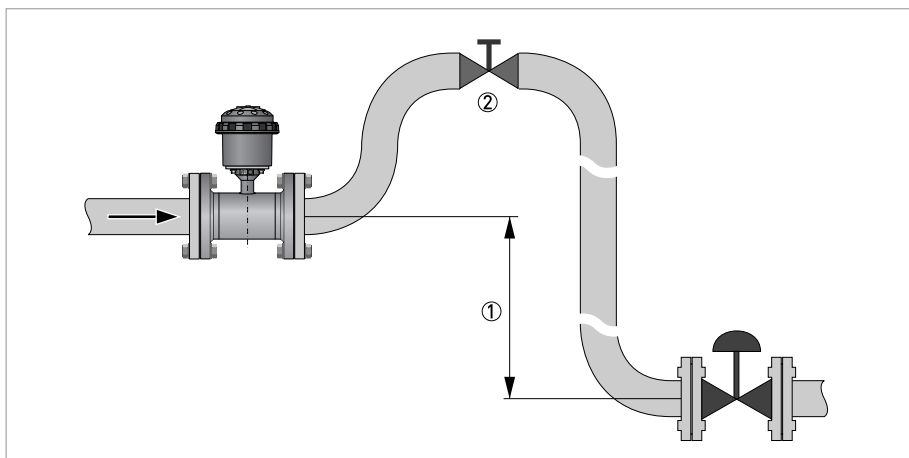

Figure 3-11: Air venting

- ①  $\geq 5$  m
- ② Air ventilation point

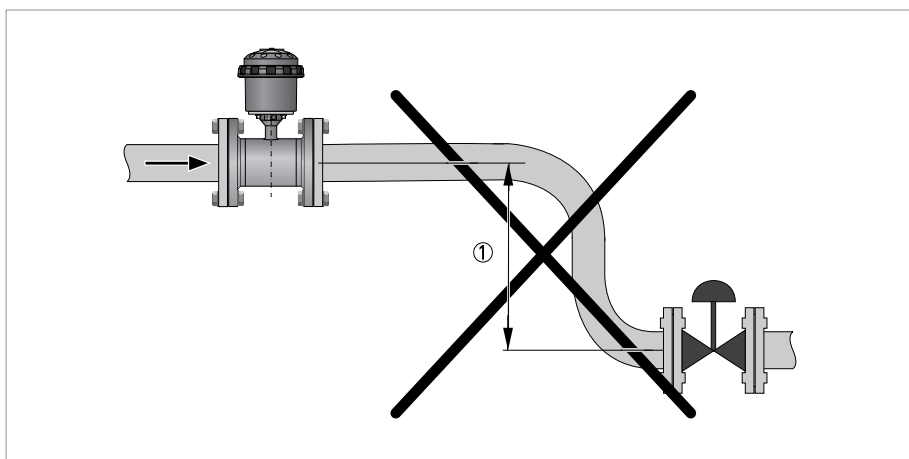

Figure 3-12: Vacuum

- ①  $\geq 5$  m

### 3.6.8 Flange Deviation

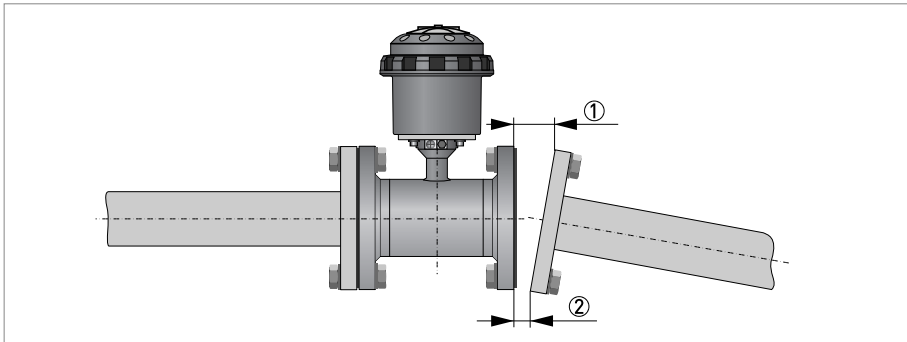

Figure 3-13: Flange deviation

- ①  $L_{max}$
- ②  $L_{min}$



**CAUTION!**

Max. permissible deviation of pipe flange faces:  $L_{max} - L_{min} \leq 0.5 \text{ mm} / 0.02''$ .



**CAUTION!**

Use the proper tools to ensure the integrity of the meter and prevent damage to the Rilsan<sup>®</sup> coating.

### 3.6.9 Mounting position

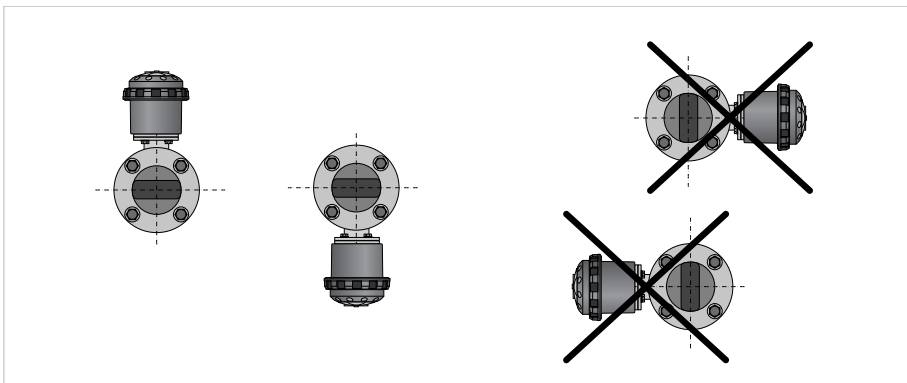

Figure 3-14: Mounting position

- Mount flow sensor either with the signal converter aligned upwards or downwards.
- Install flow sensor in line with the pipe axis.
- Pipe flange faces must be parallel to each other.

### 3.6.10 Installation in a metering pit and subsurface applications

The WATERFLUX 3000 flow sensor is IP68 rated / NEMA 4X/6P to IEC/EN 60529. It is suitable for continuous submersion in flooded measurement chambers and can withstand a 10 meter / 33 ft water column.

The compact and remote version of the IFC 070 signal converter is IP68 rated / NEMA 4/4X/6 and suitable for periodic submersion in flooded measurement chambers.

The signal converters have a polycarbonate housing and IP68 rated (military) plug and play connectors. Submersion under water is possible down to a depth of 10 meter / 33 ft. In applications with prolonged or continuous submersion, it is advised to use the WATERFLUX 3070 remote version. The remote IFC 070 signal converter and GPRS data logger unit can be installed on the wall of the measuring pit near the lid for visual read out of the display.

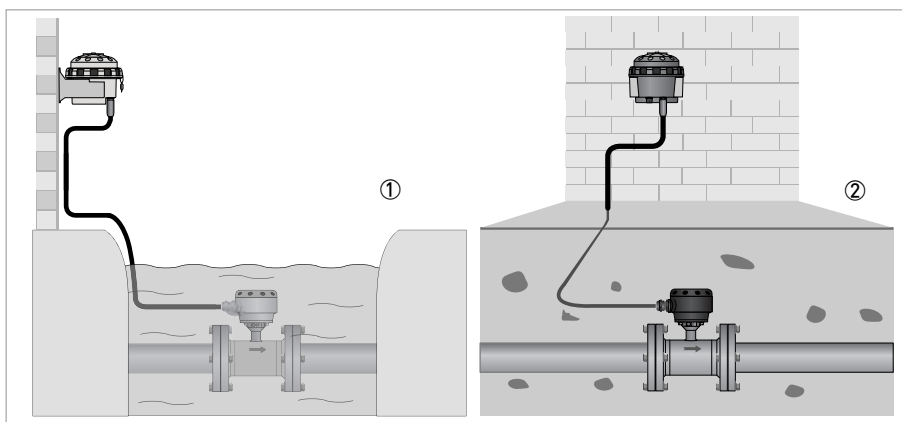

Figure 3-15: Examples of flooded and buried application

- ① Submersible
- ② Buried

### Submersion applications

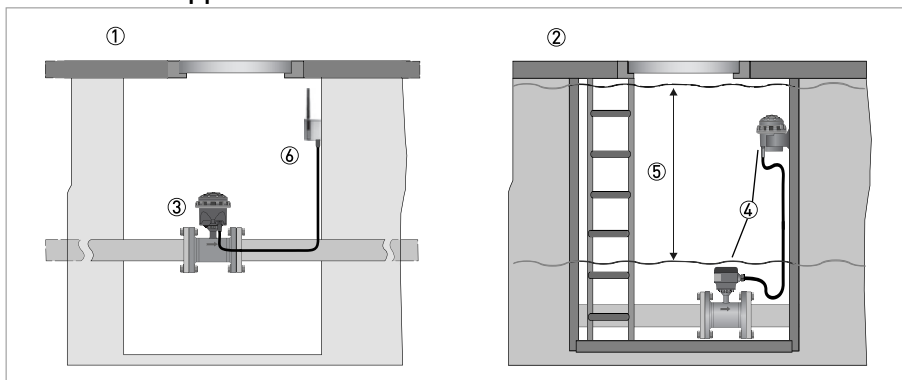

Figure 3-16: Examples of installation in measuring pit

- ① Periodic submersion
- ② Continuous submersion
- ③ Compact version
- ④ Remote version
- ⑤ Maximum water column 10 meter / 33 ft
- ⑥ GPRS / data logger unit (location)



#### CAUTION!

When installing flowmeter and GPRS/GSM module, follow supplier instructions.

## 3.7 Mounting

### 3.7.1 Torques and pressures

The maximum pressure and torque values for the flowmeter are theoretical and calculated for optimum conditions and use with carbon steel flanges.

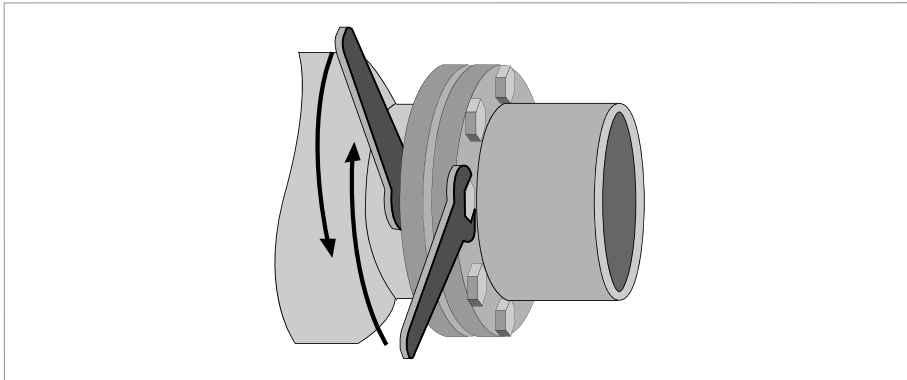

Figure 3-17: Tightening of bolts



#### Tightening of bolts

- Always tighten the bolts uniformly and in diagonally opposite sequence.
- Do not exceed the maximum torque value.
- Step 1: Apply approx. 50% of max. torque given in table.
- Step 2: Apply approx. 80% of max. torque given in table.
- Step 3: Apply 100% of max. torque given in table.

Nominal size DN [mm]	Pressure rating	Bolts	Max. torque [Nm] <sup>①</sup>
25	PN 16	4 x M 12	12
40	PN 16	4 x M 16	30
50	PN 16	4 x M 16	36
65	PN 16	8 x M 16	50
80	PN 16	8 x M 16	30
100	PN 16	8 x M 16	32
125	PN 16	8 x M 16	40
150	PN 10	8 x M 20	55
150	PN 16	8 x M 20	55
200	PN 10	8 x M 20	85
200	PN 16 <sup>②</sup>	12 x M 20	57
250	PN 10	12 x M 20	80
250	PN 16 <sup>②</sup>	12 x M 24	100
300	PN 10	12 x M 20	95
300	PN 16	12 x M 24	136
350	PN 10	16 x M 20	96
400	PN 10	16 x M 24	130
450	PN 10	20 x M 24	116
500	PN 10	20 x M 24	134
600	PN 10	20 x M 27	173

① The torque values also depend on variables (temperature, bolt material, gasket material, lubricants, etc.) outside the control of the manufacturer. Therefore these values should be regarded as indicative only.

② No full rating (max. 10 bar)



Nominal size [inch]	Flange class [lb]	Bolts	Max. torque [lbs.ft] <sup>①</sup>
1	150	4 x 1/2"	4
1½	150	4 x 1/2"	11
2	150	4 x 5/8"	18
2.5	150	8 x 5/8"	27
3	150	4 x 5/8"	33
4	150	8 x 5/8"	22
5	150	8 x 3/4"	33
6	150	8 x 3/4"	48
8	150	8 x 3/4"	66
10	150	12 x 7/8"	74
12	150	12 x 7/8"	106
14	150 ②	12 x 1"	87
16	150 ②	16 x 1"	84
18	150 ②	16 x 1 1/8"	131
20	150 ②	20 x 1 1/8"	118
24	150 ②	20 x 1 1/4"	166

① The torque values also depend on variables (temperature, bolt material, gasket material, lubricants, etc.) outside the control of the manufacturer. Therefore these values should be regarded as indicative only.

② No full rating (max. 150 psi / 10 bar).

### 3.8 Mounting of the signal converter



#### INFORMATION!

Assembly materials and tools are not part of the delivery. Use the assembly materials and tools in compliance with the applicable occupational health and safety directives.

#### 3.8.1 Remote signal converter housing

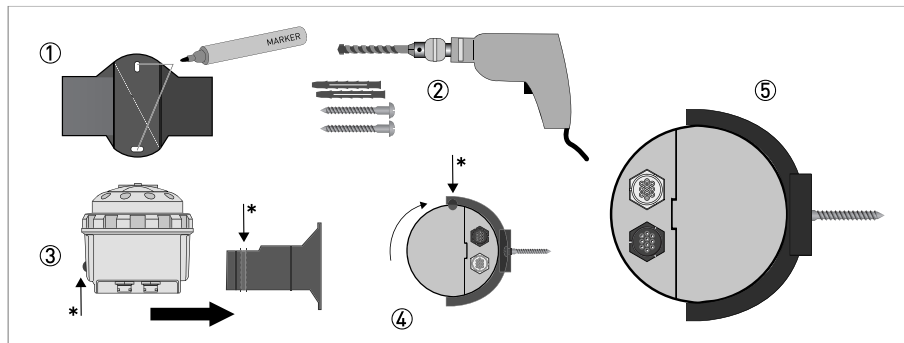

Figure 3-18: Mounting of the wall holder

- ① Mark the fixation points.
- ② Drill the holes and mount the holder with the right screws (e.g. M6 x 50 with washer) and plugs. Do not exceed a tightening torque of 2 Nm / 1.5 lb-ft when fastening the screws. This can damage the wall holder.
- ③ Slide the IP68 remote version housing into the holder as shown. Make sure that the positioning cam \* is placed in the guiding provided for that purpose (power and data connectors positioned on the backside).
- ④ Turn the housing 180° counter clockwise (until the power and data connectors are on the front side). Make sure that the holder snaps into the lock of the wall holder.
- ⑤ Bottom view of the IP68 remote version in to the wall holder.

#### 3.8.2 Closing of the signal converter housing

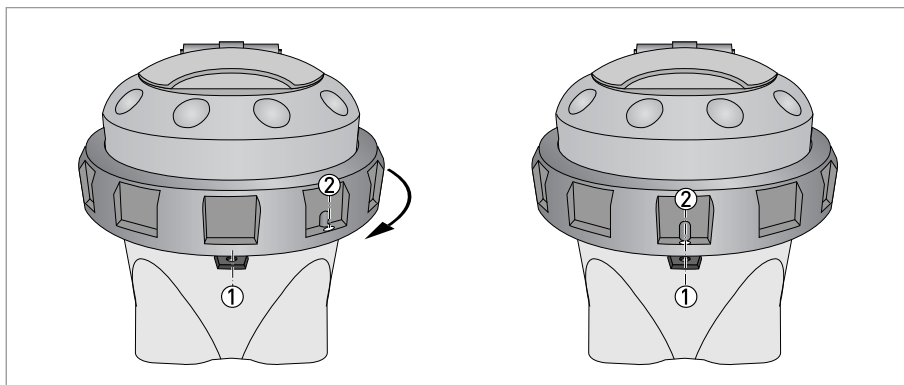

Figure 3-19: Closing of the signal converter housing



- Before closing the case of the signal converter, ensure that all surfaces in contact with the seals are clean.
- Position the upper part of the case and tighten the lock ring, up until the positions of points ① and ② are inline (do not tighten the ring any further).
- Use the special wrench to tighten the ring as advised above.
- If applicable, place a new utility seal (see section Utility Seal).

### 3.8.3 Mounting of the KROHNE FlexPower unit

The mounting of the KROHNE FlexPower unit is possible in the following options:

- Surface mounting with 2 screws on a wall or other sufficient hard surface
- On-pipe mounting with 2 Tie-Wraps

For mounting on a horizontal or vertical surface, always use the proper tools and mounting materials (e.g. drill, plug and screws). The distance between the two mounting holes is 184 mm / 7.2". Always mount the KROHNE FlexPower unit on the intended location before connecting to the flow sensor and/or switching on the main power. When attaching the wall holder unit to the wall, do not exceed a tightening torque of 1 Nm / 0.74 lb-ft when fastening the screws. This can damage the mounting eyelets.

Mounting on the pipe line construction can easily be done by using 2 Tie-Wraps. The bottom of the housing of the KROHNE FlexPower unit is designed for mounting on a pipe line. Choose the correct size and properties of the Tie-Wraps (specifications according ambient temperature and other conditions, size, width max. 14 mm / ½"). Consider releasable types of Tie-Wraps when mobility and/or replacing of mounting is expected.

The KROHNE FlexPower unit is IP68 rated.



**CAUTION!**

Prevent water ingress to the AC or DC cable when not connected.

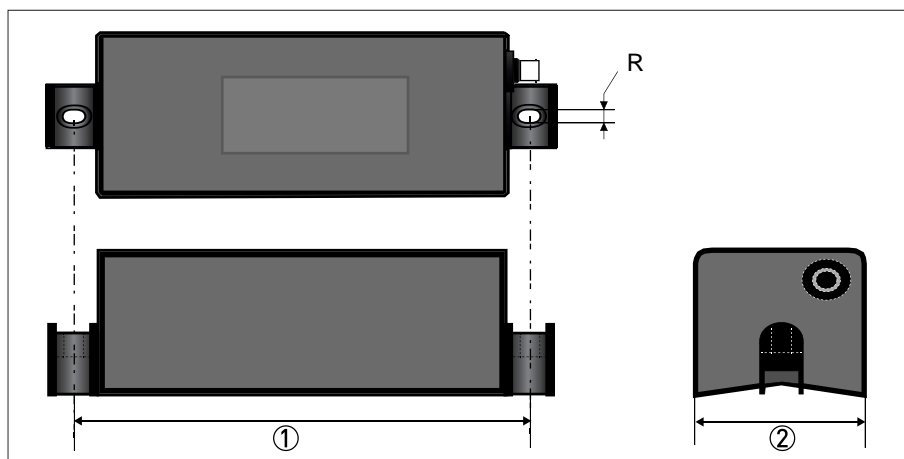

Figure 3-20: Dimensions KROHNE FlexPower

① distance = 184 mm / 7.2"

② width of unit = 74 mm / 2.9"

R = size of mounting hole; 6 mm / ¼"

## 4.1 Safety instructions

**DANGER!**

All work on the electrical connections may only be carried out with the power disconnected.  
Take note of the voltage data on the nameplate!

**DANGER!**

Observe the national regulations for electrical installations!

**WARNING!**

Observe without fail the local occupational health and safety regulations.  
Any work done on the electrical components of the measuring device may only be carried out by properly trained specialists.

**INFORMATION!**

Look at the device nameplate to ensure that the device is delivered according to your order.  
Check for the correct supply voltage printed on the nameplate.

## 4.2 Important notes on electrical connection

**DANGER!**

Electrical connection is carried out in conformity with the VDE 0100 directive "Regulations for electrical power installations with line voltages up to 1000 V" or equivalent national regulations.

**DANGER!**

Cables may only be connected when the power is switched off.

**CAUTION!**

- Use suitable cable entries for the various electrical cables.
- The measuring flow sensor and signal converter have been configured together at the factory. For this reason, please connect the devices in pairs. Ensure that the measuring flow sensor constant GK/GKL (see nameplates) are identically set.
- If delivered separately or when installing devices that were not configured together, set the signal converter to the DN size and GK/GKL of the flow sensor, refer to the chapter; **Function tables** of the concerning signal converter.

### 4.3 Grounding

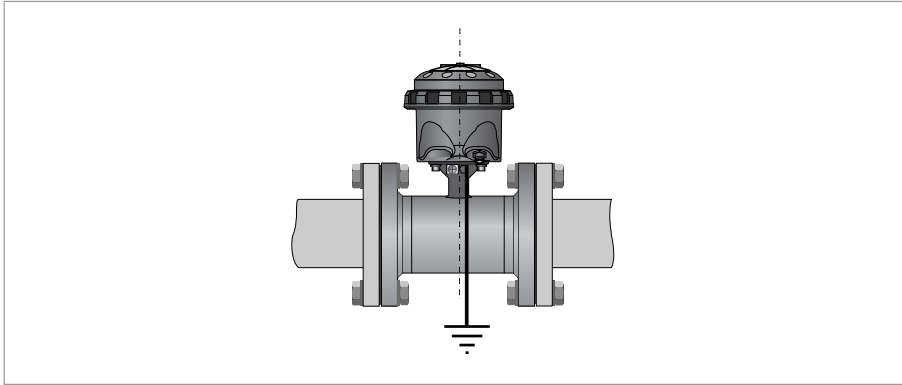

Figure 4-1: Grounding



**INFORMATION!**

*Grounding without grounding rings. The flow sensor is equipped with a reference electrode.*

## 4.4 Cable overview

The following overview describes the different cables available for the compact and remote version.

The flow sensor cable for the IP68 remote (field) version has an 8 pin male connector. The I/O cable (pulse /modbus) is available in a KROHNE FlexPower version and has an additional power cable connection.

Overview I/O cables, with or without a power cable, with female connector:

### IP68 Cable versions

I/O version	KROHNE FlexPower cable	PIN
Modbus cable	N	4
Pulse cable	N	8
KGA 42	N	8
Modbus cable	Y	10
Pulse cable	Y	8
KGA 42	Y	8

### Electrical values

- **Pulse output**  
**2x Pulse output passive - (maximum 3 outputs possible, see status output):**  
 $f \leq 100 \text{ Hz}$ ;  $I \leq 10 \text{ mA}$ ;  $U: 2.7 \dots 24 \text{ VDC}$  ( $P \leq 100 \text{ mW}$ )
- **Status output**  
**2x Status output passive - (1 status output can be used as a third pulse output):**  
 $I \leq 10 \text{ mA}$ ;  $U: 2.7 \dots 24 \text{ VDC}$  ( $P \leq 100 \text{ mW}$ )
- **Communication**  
 Modbus RTU output - (detailed information available in Supplementary Manual)
- **Optional:**  
 KGA external data logger / GSM module - (see the KGA 42 Supplementary Manual)

## 4.5 Connection of the flow sensor cable



### CAUTION!

Make sure the device functions properly, always use the signal cables included in the delivery

The compact version of the WATERFLUX 3070 is already internally connected to the flow sensor and has different options to connect pulse, Modbus and/or external supply cables. See the following sections for the different options and available cables.

For the WATERFLUX 3070 remote version, a standard cable is delivered with the device. On the flow sensor side the cable is as standard potted at the factory. The flow sensor cable has a IP68 rated stainless steel snap-on connection to connect the flow sensor with the IP68 field signal converter the cables have the following colour coded leads:

### Standard flow sensor cable

Wire colour	Terminal	Function
Brown	1	Reference electrode
White	2	Standard electrode signal
Violet	3	Standard electrode signal
Blue	7	Field current
Green	8	Field current
Yellow	9	No function
Drain wires	Screws	Shielding



### INFORMATION!

The standard WSC2 flow sensor cable (double shielded), includes both electrode and field current leads and has a maximum length of 25 m / 82 ft. (other lengths on request).

### Flow sensor cable with integrated P&T option

Wire colour	Contact on connector	Terminal	Function
Brown	H	1	Reference electrode / P&T sensor
White	D	4	P&T sensor
Grey	F	5	P&T sensor
Pink	B	6	P&T sensor
Blue	A	7	Field current
Green	G	8	Field current
White/White	C	2	Standard electrode signal
White/Red	E	3	Standard electrode signal
Drain wires	Housing	Screws	Shielding

## 4.6 Connection of the signal cable

### 4.6.1 IP68 housing (compact version)

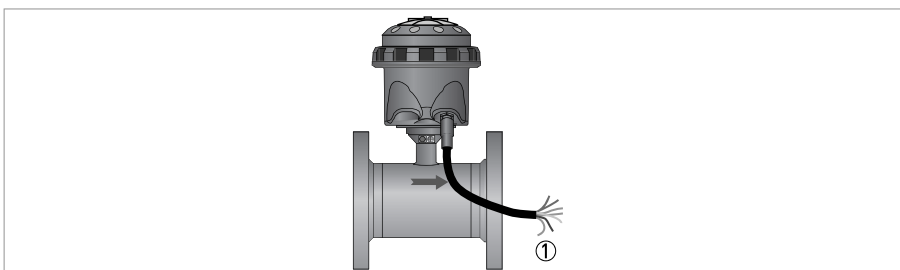

Figure 4-2: Output cable at IP68 compact version

① Color coded leads of the output cable

If an output is activated, the output cable with the IP68 rated connector has the following color coded leads:

#### Pulse output cable

Wire color	Contact on connector	Function
Yellow	A	Status output 1 or threshold for P or T or pulse output C
White	G	Status output 2 or threshold for P or T
Blue	H	Ground
Brown	B	Pulse output A
Green	F	Pulse output B
Pink	C	External battery +
Grey	E	External battery -

Note; with or without shielding

#### Modbus cable

Wire color	Contact on connector	Function
Yellow	1	Down link wire B Sign. B (D1+) ←
Grey	1	Up link wire B Sign. B (D1+) →
Pink	2	Up link wire A Sign. A (D0-) →
Green	2	Down link wire A (D0-) ←
White	3	Ground
Brown	-	-
Shield	Earth	

Note: see the next chapter for the combined power and modbus / pulse cable options.



### 4.6.2 IP68 housing (remote version)

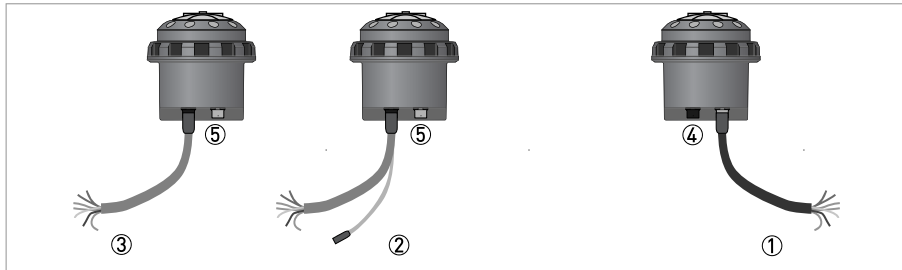

Figure 4-3: Different output cable, IP68 remote version

- ① Color coded leads of flow sensor cable
- ② Y - cable with additional power cable
- ③ I/O cable (pulse, modbus)
- ④ I/O connection
- ⑤ Stainless steel flow sensor cable connection

#### Flow sensor cable:

For more information; refer to *Connection of the flow sensor cable* on page 31 for the available connection options.

For connection of I/O (modbus, pulse output signals) with or without additional power supply cable connection, several cable connection options are available. The cables have the following color code leads.

#### Output pulse cable

Wire color	Contact on connector	Function
Yellow	A	Status output 1 or threshold for P or T or pulse output C
White	G	Status output 2 or threshold for P or T
Blue	H	Ground
Brown	B	Pulse output A
Green	F	Pulse output B
Pink	C	External battery +
Grey	E	External battery -

#### Modbus cable

Wire color	Contact on connector	Function
Yellow	1	Down link wire B Sign. B (D1+) ←
Grey	1	Up link wire B Sign. B (D1+) →
Pink	2	Up link wire A Sign. A (D0-) →
Green	2	Down link wire A Sign. A (D0-) ←
White	3	Ground
Brown	-	-
Shield	Earth	

**Combined power and pulse output cable (Y-cable)**

Wire color	Contact on connector	Function
Yellow	A	Status output 1 or threshold for P or T or pulse output C
White	G	Status output 2 or threshold for P or T
Grey	H	Ground
Brown	B	Pulse output A
Green	F	Pulse output B
Brown	C	External power +3.6V
White	E	External power (Ground)
Shield	D	Shielding

**Combined power and Modbus cable (Y-cable)**

Wire color	Contact on connector	Function
Shield	C	Shielding
Brown	B	-
White	A	Ground
Green	E	Down link wire A Sign. A (D0-) ←
Yellow	K	Down link wire B Sign. B (D1+) ←
Pink	H	Up link wire A Sign. A (D0-) →
Grey	J	Up link wire B Sign. B (D1+) →
Brown	F	External power +3.6V
White	G	External power (Ground)
Shield	D	Shielding

This cable has two pairs of wires, one for uplink and one for downlink. Both are connected within the connector. When disconnecting the cable on the flow sensor side, the two paired wires will stay connected so there is disconnection of the RS-485.

Because of this connection (switching link wire), it makes no difference where the up- and downlink are connected.

**INFORMATION!**

*For proper use and installation, it is recommended to follow the advised color coded wire connections in the table above. A 120 Ω line terminator is required when the WATERFLUX 3070 signal converter is the last device in line and/or is part of the bus connection.*

*Specific information is described in the supplementary Modbus manual, available on the manufacturer website.*

## 5.1 Connecting the internal battery



### CAUTION!

Please connect the battery before first use. The signal converter is delivered with a disconnected battery.



### INFORMATION!

For transport purposes signal converters which are verified to MI-001 or OIML R49 have also disconnected batteries. Please connect battery before placing the local utility seal.

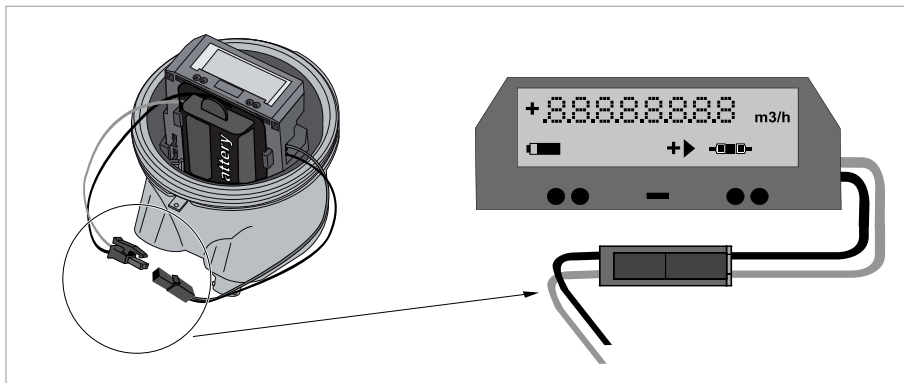

Figure 5-1: Connecting the battery



- Remove the cover.
- Fasten the battery connector of the power cable to the internal connector in the signal converter.
- Check if the display lights up.
- Put back the cover.



### WARNING!

Make sure that the battery cable is not jammed by the cover.



- For closing the case of the device in the IP68 housing refer to *Closing of the signal converter housing* on page 26.

For information on the different battery types refer to *Types of batteries* on page 65.



### INFORMATION!

The device now operates with default menu settings.

For configuration of these menu settings refer to *Battery settings* on page 62.

## 5.2 Connecting the external battery

### 5.2.1 IP68 housing (compact and remote version)

The output cable has two color coded leads for connecting the external battery.

For detailed information refer to *IP68 housing (compact version)* on page 32 and refer to *IP68 housing (remote version)* on page 33.

For more information regarding the battery menu settings refer to *Battery settings* on page 62.

## 5.3 Power supply - battery

The standard version of the WATERFLUX 3070 has an internal battery pack with a Lithium double D cell (3.6V-38 Ah). Optional an KROHNE PowerBlock (Lithium Dual DD cell 3.6V-70 Ah) can be connected with an IP68 rated, 1.5 meter long cable. There is no loss of totalizer data when exchanging and/or replacing battery/power supply.

More information regarding the exchange / replacing of battery, refer to *Types of batteries* on page 65 or refer to *Battery lifetime* on page 94 for typical lifetimes of batteries.

## 5.4 Power supply - KROHNE FlexPower



### **WARNING!**

*Fire, explosion and severe burn hazard. Do not recharge, disassemble, or heat above 70 °C / 158 °F. Do NOT incinerate or expose contents to water.*

Beside regular battery power supplies, the WATERFLUX 3070 can also be connected to an external KROHNE FlexPower unit.

The external KROHNE FlexPower unit has an internal Lithium battery pack (3.6 V -38 Ah) and can be connected with a combined power and output cable (Y-cable) for power input. The unit is delivered with a special power cable for connection to a 10...30 V DC supply (a.o. through wind-and/or solar energy supplies) and a cable for connecting to mains supply (110...230 V AC / 50 - 60 Hz)

The FlexPower unit has two, not rechargable internal batteries (3.6 V -38 Ah) for battery backup mode. There is no loss of totalizer data when connecting / disconnecting the KROHNE FlexPower unit.



Figure 5-2: KROHNE FlexPower supply

### 5.4.1 Connection of the FlexPower unit

**DANGER!**

*Observe the notes as described in this section with respect to the installation and connection of the AC and/or DC supply!*

**CAUTION!**

*Rout non connected cables back to the power distribution box. Install cables correctly even when no power is to be connected!*

*Take measures to prevent water ingress and shock hazard on AC and/or DC cables when not connected.*

Optionally, beside an internal or external battery, the WATERFLUX 3070 can be connected to an external FlexPower unit for mains power and/or DC power operation with battery back-up.

The input power for the KROHNE FlexPower can be realized by connection to an AC/DC supply source:

- AC mains supply source: 110...230 V AC - 50/60 Hz
- DC supply source: 10...30 V DC

Automatically a start-up routine is followed, when the WATERFLUX 3070 with the FlexPower is connected properly to a live AC and/or DC supply. First the DC input is checked and if present and AC/DC converter active, the power source is DC. When AC power is present and AC/DC converter active, the power source is AC/DC. If both are not available (interrupted) the internal dual D-cell battery pack (3.6V - 38 Ah) automatically takes over the power supply.

To save energy, the WATERFLUX 3070 will automatically switch to the low power consuming battery backup mode and will continue to totalize volumes but temporarily stop to transfer the data.

The FlexPower unit is IP68 rated and totally sealed and potted to prevent ingress of water. Therefore the integrated batteries cannot be changed.

### Power input / output

The 3.6V **DC power output** of the FlexPower can easily be connected with the cable assembly that is delivered with the FlexPower unit. The UTS snap-on connector of the cable fits in only one way to the female connector on the FlexPower unit.

As described, **the power input** of the FlexPower can either be chosen an AC and/or DC input. To prevent water ingress and/or shock hazard, both cable ends are IP68 sealed. If possible, it is advised to connect both AC and DC inputs on the main power source.

When one of the input cables remain disconnected, make sure that this cable is correctly installed to prevent damage to the IP68 sealed end.

### DC power cable (green cable)

Wire color	Connection
Red	DC (+)
Blue	DC (+)
Yellow/Green	FE (functional earth)

### AC power cable (grey cable)

Wire color	Connection
Black 1	AC (~)
Black 2	AC (~)
Green/Yellow	PE (protective earth)

Cable  $\varnothing = 0.75 \text{ mm}^2$

## 5.5 Starting the signal converter

The measuring device consist of a flow sensor and a signal converter and is ready for operation. When the power is switched on (battery or FlexPower unit is connected), a self-test is carried out and after that the meter starts to operate.

## 6.1 Display and operating elements

The IFC 070 signal converter has a display and two optical keys. The optical keys can be used to cycle the display and to access the menu.

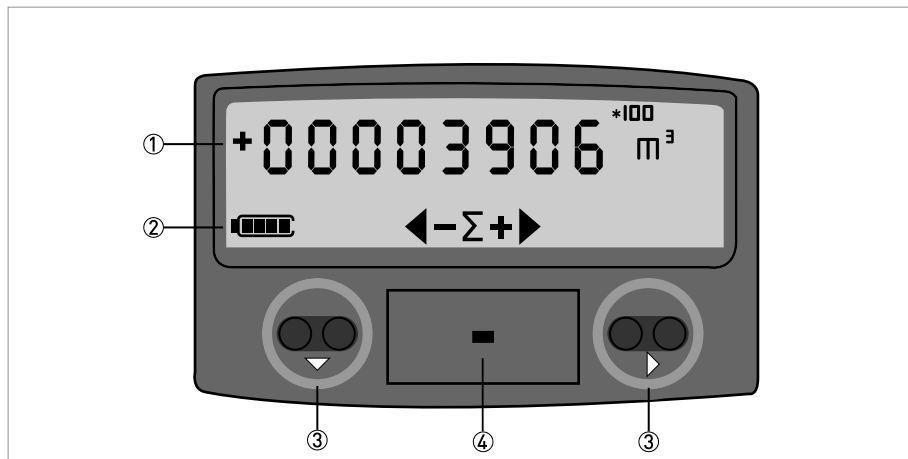
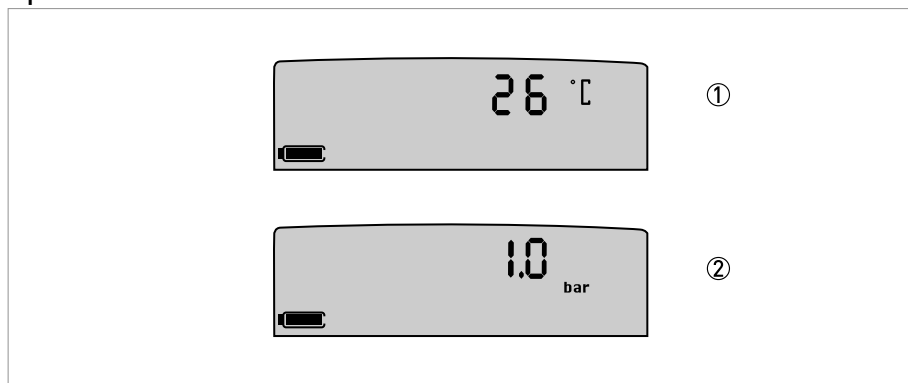

Figure 6-1: Display and operating elements

- ① Counter value or flow rate
- ② Status information including battery status, flow direction and counter settings
- ③ Optical keys ◀ and ▶ to navigate the menu and for display options
- ④ Reset button only accessible after removing the housing

### Optional P&T sensor



- ① Display showing temperature value
- ② Display showing pressure value

### 6.1.1 Show counters and flow rate on the display

Depending on the settings, the display shows the sum counter and optionally the forward and reverse counter and the flow rate. In addition, the display shows the unit of measurement, direction of the flow, and if selected, a decimal point or a multiplier value.



#### Set display to a different counter or to flow rate:

- Press the left optical key  $\blacktriangledown$  for 1 second to cycle to the next display.
- Leave the optical key untouched, to keep the current display.
- If the meter is set to AMR mode, the display will always switch back to the sum counter display.

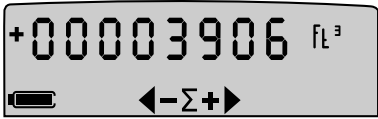
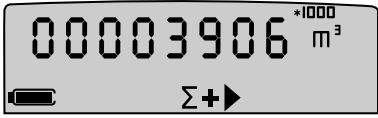
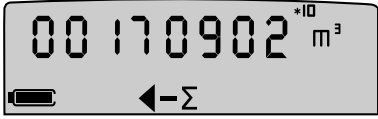
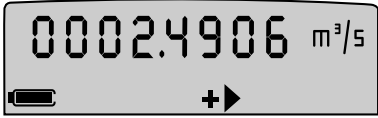
Display	Description	Menu setting
	Sum counter (default)	Always available
	Forward counter	Available if menu number 13 is set to 1
	Reverse counter	Available if menu number 14 is set to 1
	Positive flow rate	Available if menu number 17 is set to 1

#### Display symbols for flow direction and counter settings

Flow direction is from left to right (default)	Flow direction is from right to left	Description
$\blacktriangleleft - \Sigma + \blacktriangleright$	$\blacktriangleleft + \Sigma - \blacktriangleright$	Sum counter (default)
$\Sigma + \blacktriangleright$	$\blacktriangleleft + \Sigma$	Forward counter
$\blacktriangleleft - \Sigma$	$\Sigma - \blacktriangleright$	Reverse counter
$+ \blacktriangleright$	$\blacktriangleleft +$	Positive flow rate
$\blacktriangleleft -$	$- \blacktriangleright$	Negative flow rate



### 6.1.2 Show software version, diameter, meter constant and display test on the display





To cycle through the displays:



- Press the right optical key ▶ for 1 second to cycle to the next display
- Leave the optical key untouched at any time to return to the main display.

Display	Description
	Example of the instrument serial number
	Example of the software version
	CrC (cyclic redundancy check) integrity test of the memory and software. Example; CrC CFF7 is SWR 5.0.3_
	Example of the diameter (125) and the meter constant (4.160)
	Example of the add-on software version
	Example Modbus version
	Display test

## 6.1.3 Status information on the display

Display symbols	Description	Menu setting
	Battery status	Always available
<b>AMR</b>	AMR mode on	Available if menu number 2 is set to 1
	Automatic self-test	Automatically Please refer to <i>Automatic self-test</i> on page 64.
<b>TEST</b>	Test mode on	To activate Please refer to <i>Test mode</i> on page 64.

## Error and notification messages

Display	Description	Actions
<b>1year 1year 1year 1year</b> 	At the current consumption rate, the battery will be empty within 1 year.	Plan battery replacement. Note: this sign can also appear for a short period if the battery consumption is temporarily very high.
	Battery nearly empty	Replace the battery
<b>E-00</b>	Battery empty: voltage too low	
<b>!</b> (Flashing)	Notification!	<ul style="list-style-type: none"> <li>• Check all connections</li> <li>• If the exclamation mark does not disappear, contact the service department</li> </ul>
<b>E-X</b> (X = 1...127)	Impaired software integrity	The meter has stored the last counter values and went to sleep mode. Contact the service department.
<b>-EP-</b>	Empty pipe	Available if menu number 83 is set to 1.
<b>°C</b> or <b>bar</b>	When the pressure/temperature is above or below max/min of the specified threshold values, the display will show the applicable max/min calibrated value, blinking ON/OFF	Check system and make sure not to exceed P/T range. (0.5...16 bar/ -5...+70°C)
<b>- - -</b>	When pressure/temperature is not read out correctly (or not read out yet from the P&T sensor) the display will show some dashes to indicate there is no valid data available	<ul style="list-style-type: none"> <li>• Check all connections</li> <li>• If the exclamation mark does not disappear, contact the service department.</li> </ul>

## 6.2 Access control

Access to the hardware and the software of the WATERFLUX 3070 can be limited or blocked to prevent intervention by non-authorized persons. The hardware can be blocked with metrology or utility seals. Menu access to the parameters relevant for fiscal metering can be blocked in the software.

### 6.2.1 Access levels to the menu

There are three levels of menu access:

Access levels to the menu	Menu settings
Full menu access	Menu number 1 is set to 0
Access to the service menu only	Menu number 1 is set to 1
	Use a jumper to gain access to the service menu
Menu access blocked	Menu number 1 is set to 1

### 6.2.2 Access to the service menu only

It can be necessary to access the menu for service purposes if the menu access is blocked. For this purpose, a service menu is available. The service menu becomes available after placing a jumper inside the signal converter housing. The service menu gives no access to items that are subject to legal metrology.



#### **INFORMATION!**

*Be careful not to accidentally break the metrological seals while moving the jumper. Breaking the metrological seals could mean that the meter needs to be re-verified. For detailed information, please check your local regulations.*

For an overview of menu items available in the service menu refer to *Menu overview* on page 48.



- ① No jumper, menu access blocked
- ② Jumper setting to gain access to the service menu
- ③ Storage location for the jumper. Menu access is blocked

### 6.2.3 Meters subject to metrology

After verification to MID Annex III (MI-001) or the OIML R49, hardware and software components that are critical for measurement characteristics and metrologically important parameters need to be protected against intervention such as accidental or intentional corruption during operation.

If the meter has been verified to MID Annex III (MI-001), access to the programming menu of the software containing the metrologically relevant parameters is blocked at the factory after the Module D verification procedure:

- Menu number 1 (access control) is set to 1
- Metrological seals are placed

Access to the service menu, without breaking the metrological seals is possible by placing the jumper. Parameters subject to fiscal metering are not available via the service menu.

The software version, diameter and meter constant are fiscal parameters. These values can be read on the display and checked with the values on the name plate without breaking the sealing. For more information please refer to *Show software version, diameter, meter constant and display test on the display* on page 41.

### 6.2.4 Metrological seals

After a meter is verified to MID Annex III (MI-001) or the OIML R49, the following metrological seals are applied on:

- The access hole to the reset switch that allows access to the parameter settings.
- The electronic units against removal from the outer housing of the water meter.
- The name plate and the housing of the meter to secure the nameplate against removal.



#### **INFORMATION!**

*Breaking the metrological seals could mean that the meter needs to be re-verified. For detailed information, please check your local regulations.*

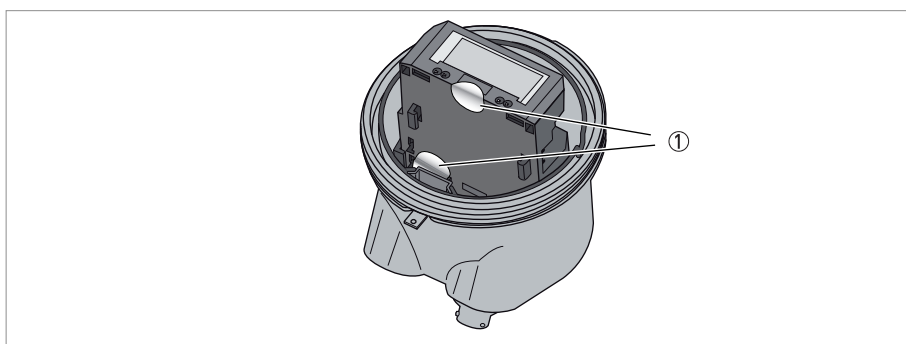

Figure 6-2: Metrological seals in signal converter housing

- ① Location of seals

### 6.2.5 Utility seals

To prevent intervention by non-authorized persons to the hardware and software, measures can be taken after installation and commissioning of the water meter in the field. For detailed information, please check your local regulations.

The following figures provide an example for additional utility seals. A utility seal on the outer housing of the signal converter and a utility seal on the measurement flow sensor can provide evidence of an intervention by a non-authorized person.

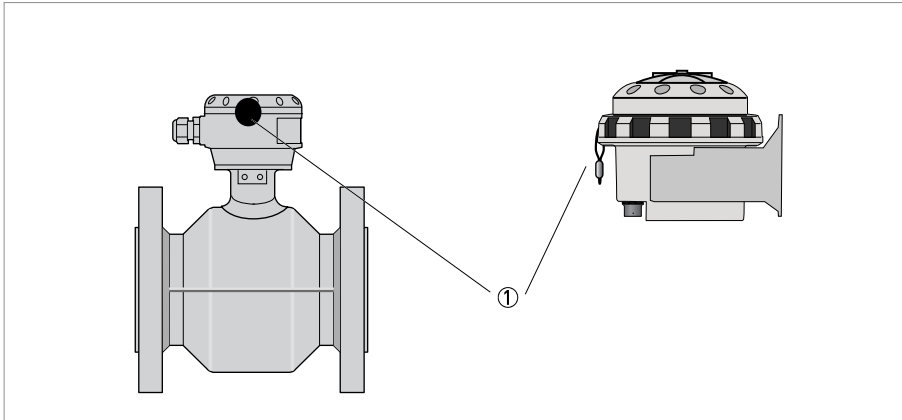

Figure 6-3: Examples of a utility seal with the remote version

① Location of seals

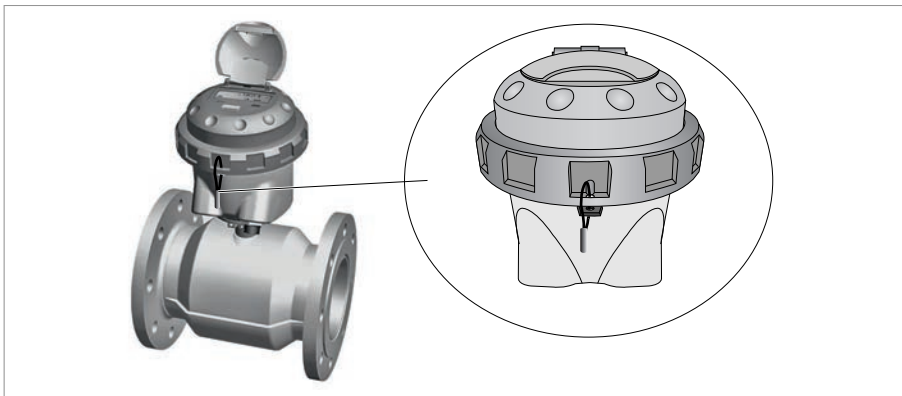

Figure 6-4: Example of a utility seal

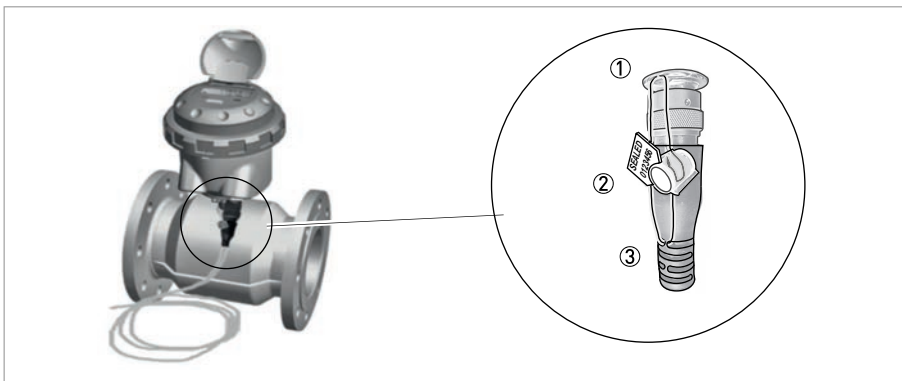

Figure 6-5: Utility seal on snap-on plug connection

- ① Steel sealing wire through housing connector
- ② Twister security meter seal
- ③ Steel sealing wire through strain relief of connector

## 6.2.6 Reset full access to the menu

**WARNING!**

Do not break the metrological seals if the meter has been verified to MID Annex III (MI-001) or OIML R49 and has received metrological sealing. This can lead to the obligation to re-verify the meter. Please check your local regulations.

To enable access to the menu again, follow the next steps:



- Remove the cover.
- Use a small screwdriver to press the reset button.  
First press the reset button ① and then simultaneously press both the optical keys for 6 seconds ②.
- The display will automatically switch to menu number 1.
- To change the setting of menu number 1 from 1 to 0, please refer to *View or change menu settings* on page 47.

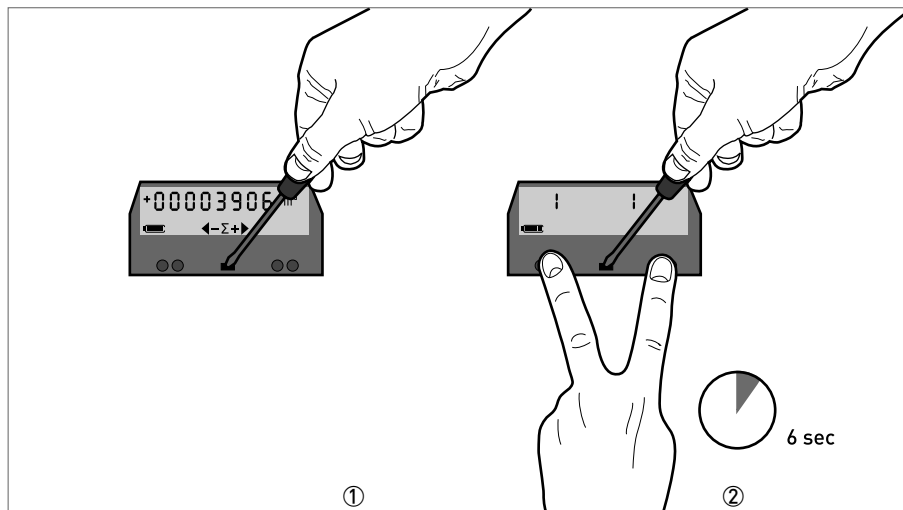

Figure 6-6: Change the settings of the access control.

**WARNING!**

Make sure that the battery cable is not jammed by the cover.



- For closing the case of the signal converter in the IP68 housing, please refer to *Closing of the signal converter housing* on page 26.

## 6.3 Menu

This chapter describes:

- How to view or change menu settings.
- A menu overview including menu access levels and default settings.
- Options for menu settings are explained in following subchapters.

### 6.3.1 View or change menu settings



**CAUTION!**

Access to the programming mode of the software is blocked if menu number 1 is set to 1. This is done at the factory after the Module D verification procedure when the meter is verified to MID Annex III (MI-001) or OIML R49.

To reset full access to the menu please refer to *Reset full access to the menu* on page 46.

To navigate or change menu settings follow the next steps:

Function	Keys	Display
To start the programming mode	Hold the ▼ and the ► key for 5 seconds.	The display flashes.
To enter the menu	Press the ► key within 3 seconds.	Left: menu number Right: menu setting
To navigate through the menu to the required menu number	Press the ▼ key.	
To change the menu setting	Press the ► key.	The menu setting starts to flash.
To select the menu setting	Press the ▼ key.	The new menu setting starts to flash.
To confirm the menu setting	Hold the ► key for 3 seconds.	The menu setting no longer flashes.
To leave the programming mode and to store the new value(s)	Hold the ▼ key for 3 seconds.	The display returns to the main screen.
To leave the programming mode without storing the new value(s)	Do not touch any key for 60 seconds.	The display returns to the main screen.

## 6.3.2 Menu overview

## Access levels to the menu:

	Items only available with full menu access
	Items available in the service menu (and with full menu access)

Software version 5.0.6_			
No.	Function	Default	Description
<b>Access control</b>			
1	Access control	0	Full menu access
<b>AMR mode (Automatic Meter Reading)</b>			
2	AMR mode	0	Off
3	AMR digits	8	Use all digits
<b>Counters and flow rate</b>			
10	Counter: unit of volume	01	m <sup>3</sup>
11	Counter: number of decimals	99	Automatically
12	Counter: multiplier value	99	Automatically
13	Show forward counter	0	Off
14	Show reverse counter	0	Off
15	Flow rate: unit of volume / time	0102	m <sup>3</sup> /h
16	Flow rate: unit of time	99	Automatically
17	Show flow rate	0	Off
<b>Pulse output</b>			
20	Pulse output A	0	Off
21	Pulse output B	0	Off
22	Pulse output A and B: phase shift	0	90° offset
23	Pulse output A and B: pulse width	5	5 ms
24	Pulse output A and B: pulse value	00.100	Automatically
25	Pulse output A and B: pulse generation	99	Automatically
30	Pulse output C	0	Off
31	Pulse output C: unit of volume	01	m <sup>3</sup>
32	Pulse output C: pulse width	5	5 ms
33	Pulse output C: pulse value	00.100	Automatically



<b>Status output</b>			
40	Status output 1: self-check	0	Off
41	Status output 1: battery pre notification	0	Off
42	Status output 1: battery final notification	0	Off
43	Status output 1: empty pipe	0	Off
44	Status output 1: P&T notification	0	Off
50	Status output 2: self-check	0	Off
51	Status output 2: battery pre notification	0	Off
52	Status output 2: battery final notification	0	Off
53	Status output 2: empty pipe	0	Off
54	Status output 2: P&T notification	0	Off
<b>Pressure and temperature (optional)</b>			
60	Pressure sensor	0	Off
61	Pressure unit	00	bar / psi (1 decimal)
62	Pressure limit, Maximum	xx.x / xxx	16.0 bar / 232 psi
63	Pressure limit, Minimum		-0.5 bar / -7.3
64	Show pressure	0	Off
65	Temperature sensor	0	Off
66	Temperature unit	00	°C / °F
67	Temperature limit, Maximum	xxx	70°C / 158°F
68	Temperature limit, Minimum	xxx	-5°C / 23°F
69	Show temperature	0	Off
70	P&T measuring rate	15	15 minutes
<b>Measurement settings</b>			
80	Flow direction	0	Forward
81	Measurement interval	15	15 sec
82	Low flow cut off	10	10 mm/s
83	Empty pipe detection (EP)	0	Off
<b>Meter configuration</b>			
91	Meter size	xxx	Factory setting
92	Meter constant	xx.xxx	Factory setting
93	Zero offset calibration	0	Confirm
94	Zero selection	0	Factory setting (calibration settings)

<b>Service and test</b>			
A0	Simulate outputs	0	Off
A1	Reset all counters	88888	Confirm
A2	Flow verification on site	0	Off
A3	Add-on communication	0	Off
<b>Battery</b>			
B0	Battery type	2	Internal single batteries
B1	Battery capacity	038.00	38 Ah
B2	Reset battery lifetime counter	0	Confirm
B3	Modbus operation at power failure	0	Off

<b>Modbus RS485</b>			
C0	Modbus slave adress	001	Value to be programmed (1 to 247)
C1	Baud rate	9.6	9600 baud
C2	Parity rate	0	Even
C3	Register format	1	Big endian
C4	Transmission delay	50	50 ms
C5	Stop bits	1	1 Stop bit
C6	User application name	00000	To be set
C7	RS485 bus termination	0	No RS485 termination
C8	Reception interval	0	Set (0-3600 sec)

### 6.3.3 Access control

No.	Function	Options	Description
1	Access control	0 = Full menu access (default) 1 = Menu access blocked Fiscal metering / Custody transfer	If set to 1, access to the programming mode is blocked. To reset access to the menu please refer to <i>Reset full access to the menu</i> on page 46.

### 6.3.4 Automatic Meter Reading mode (AMR)

The AMR mode provides an option to read the display as base for the pulse output (e.g. use certain digits of the counter value).

In Automatic Meter Reading (AMR) mode the following settings apply:

- Menu number 10 (Counter: unit of volume) cannot be set to litre or acre-inch.
- Menu number 15 (Flow rate: unit of volume / time) cannot be set to litre per second or acre-inch per day.

No.	Function	Options	Description
2	AMR mode	0 = Off (default) 1 = On	Automatic Meter Reading mode (AMR)
3	AMR digits	8	Use all digits 87654321
		7 -	Use 7 most significant digits 8765432-
		- 7	Use 7 least significant digits -7654321
		6 - -	Use 6 most significant digits 876543--
		- 6 -	-765432-
		- - 6	--654321
		5 - - -	87654---
		- 5 - -	-76543--
		- - 5 -	--65432-
		- - - 5	---54321
		4 - - - -	8765----
		- 4 - - -	-7654---
		- - 4 - -	--6543--
		- - - 4 -	---5432-
		- - - - 4	----4321

### 6.3.5 Counters and flow rate

The following preferences are available:

- Unit of volume or time
- Accuracy of the counters
- Multiplier value
- Availability of forward and reverse counter and flow rate on the display

The counter values can be programmed to display a higher accuracy with a decimal dot (menu number 11). The multiplier value enables the display of volumes with more than 8 digits (menu number 12).

If a multiplier is selected, the multiplier value is shown in the top right corner of the display. The value on the display must be multiplied with a factor 10, 100 or 1000 to get the actual counter value. The decimal dot and multiplier value are not available for the flow rate.

The default setting for number of decimals and the multiplier value is 99. The number of decimals and multiplier are set automatically by the software, based on the following criteria:

- The meter size and the measurement unit.
- The elapsed time to display overflow is minimal 6 years at a flow velocity of 3 m/s.
- The number of decimals is as high as possible.
- The multiplier (\*10, \*100, or \*1000) can be used only if the number of decimals is zero.

No.	Function	Options	Description
10	Counter: unit of volume	00 = Litre (l) 01 = Cubic meter (m <sup>3</sup> ) (default) 02 = Gallon (gal) 03 = Imperial gallon (i.gal) 04 = Cubic feet (ft <sup>3</sup> ) 05 = Acre feet (a-ft) 06 = Acre inch (a-in) 07 = Mega litre (Ml) 08 = Mega imperial gallon (M i. gal)	00 and 06 are not shown if menu number 2 (AMR) mode is set to 1 (On). Note: the representation of the values (number of decimals) and the multiplier are automatically set. This can be adjusted using menu items 11 and 12.
11	Counter: number of decimals	99 = Automatically (default) 0..7 = Number of decimals	Places a decimal dot. 99 = The number of decimals is set automatically.
12	Counter: multiplier value	99 = Automatically (default) 1 = x 1 10 = x 10 100 = x 100 1000 = x 1000	Shows counter value divided by the multiplier value entered.
13	Show forward counter	0 = Off (default) 1 = On	Makes the item available on the display.
14	Show reverse counter	0 = Off (default) 1 = On	Makes the item available on the display.

No.	Function	Options	Description
15	Flow rate: unit of volume / time	0000 = Litre per second (l/s)	0000 and 0603 are not shown if menu number 2 (AMR) mode is set to 1 (On). Note: in the representation of the flow rate on the display, the unit of time is automatically chosen. The default unit of time can be overruled using menu number 16. The number of decimals is fixed and cannot be changed.
		0102 = Cubic meter per hour (m <sup>3</sup> /h) (default)	
		0201 = Gallon per minute (gal/min)	
		0301 = Imperial gallon per minute (i.gal/min)	
		0402 = Cubic feet per hour (ft <sup>3</sup> /h)	
		0503 = Acre feet per day (a-ft/d)	
		0603 = Acre inch per day (a-in/d)	
		0703 = Mega litre per day (ML/d)	
16	Flow rate: unit of time	99 (default)	99 = Value is based on menu number 15 (flow rate) and diameter.
		00 = per second	
		01 = per minute	
		02 = per hour	
		03 = per day	
17	Show flow rate	0 = Off (default)	Makes the item available on the display.
		1 = On	

### 6.3.6 Pulse output

By default two pulse outputs A and B are available. Optionally, status output 1 is available as a third pulse output C.

The relation between pulse output A and B can be set in menu number 22 to the following pre-sets:

#### Pulse output A and B; 90° offset (default value)

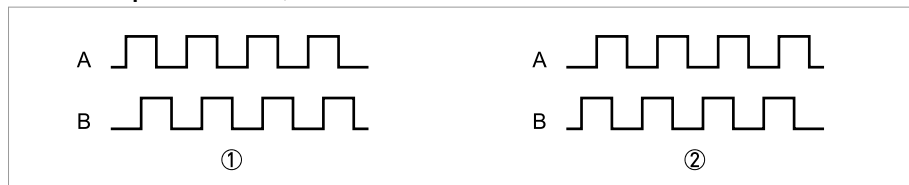

- ① Forward flow
- ② Reverse flow

There is a phase shift of 90° offset between pulse output A and B. Pulse output A and B give the same number of pulses, but pulse output B is shifted half a pulse width in time. In case of forward flow, pulse output B runs behind pulse output A. In case of reverse flow, pulse output A runs behind pulse output B.

If after a phase shift (90°) pulse output A runs behind pulse output B, the number of pulses need to be subtracted from the total, to get the net volume, equal to the sum counter on the display.

#### Pulse output A and B; Forward - Reverse

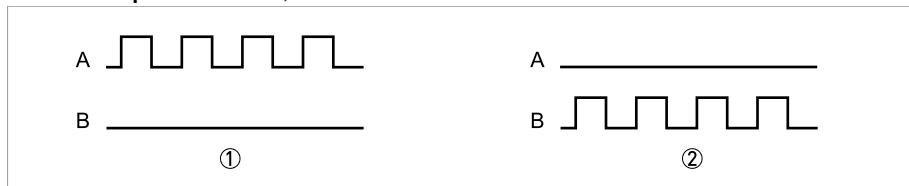

- ① Forward flow
- ② Reverse flow

Pulse output A gives the forward volume and pulse output B gives the reverse volume passing through the meter. For a net volume, equal to the sum counter on the display, the pulses provided by pulse output B need to be subtracted from the pulses provided by pulse output A.

#### Pulse output A and B; Net forward volume

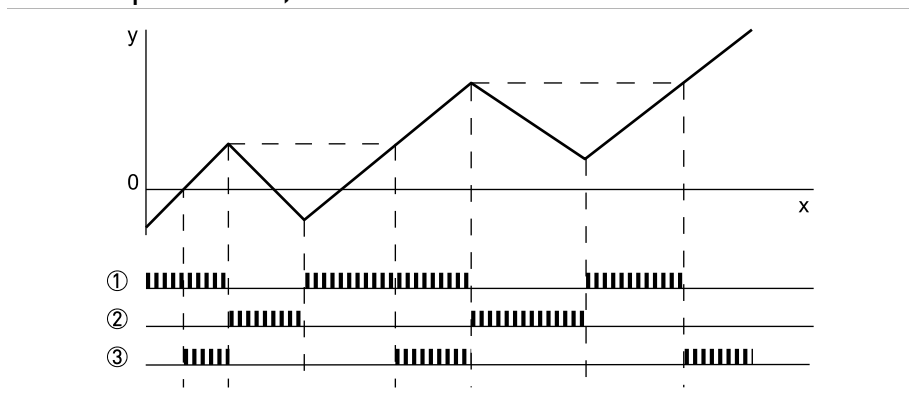

Figure 6-7: Y: Sum counter value; X: Time

- ① Forward flow
- ② Reverse flow
- ③ Net forward volume

Pulse output A and B give the same number of pulses, but pulse output B is shifted half a pulse width in time. Pulse output B always runs behind pulse output A.

In case of a forward flow, pulse output A and B give the forward volume passing through the meter.

In case of a reverse flow, pulse output A and B only start to give pulses again after the sum counter has reached the previous maximum net volume.



**INFORMATION!**

*In case of net forward volume the sum counter on the display can temporarily be different from the net volume provided by pulse output A and B.*

No.	Function	Options	Description
20	Pulse output A	0 = Off (default)	Pulse output A
		1 = On	
21	Pulse output B	0 = Off (default)	Pulse output B
		1 = On	
22	Pulse output A and B: phase shift	0 = 90° offset (default)	Sets the relation between pulse output A and B. Menu no. 20 and 21 must be set to 1 = on.
		1 = Forward - reverse	
		2 = Net forward volume	
23	Pulse output A and B: pulse width	5 = 5 ms (default)	The pulse width is always the same for pulse output A and B. A small pulse width means a lower energy consumption of the battery.
		10 = 10 ms	
		20 = 20 ms	
		50 = 50 ms	
		100 = 100 ms	
		200 = 200 ms	
24	Pulse output A and B: pulse value	00100 = litre	Unit and format are automatically set based on the selection made in menu number 10.
		00.100 = m <sup>3</sup> /pulse	
		0010.0 = gallon	
		0010.0 = imp. gallon	
		001.00 = ft <sup>3</sup>	
		.00100 = a-inch	
		.00100 = a-ft	
		.00100 = megalitre	
		00100 = mega imperial gallon	
		0.1000 = m <sup>3</sup> /pulse	When menu item A2 is set on 1

No.	Function	Options	Description
25	Pulse output A and B: pulse generation	99 = Automatically set (default)	Pulse output reacts as set in menu number 24
		1	*****1 (A pulse is generated if the least significant digit changes)
		2	*****2*
		3	*****3**
		4	****4***
		5	***5****
		6	**6*****
		7	*7*****
		8	8***** (A pulse generated if the most significant digit changes)
30	Pulse output C	0 = Status output (default)	Sets status output 1 as status output (select 0) or as pulse output (select 1, 2 or 3).
		1 = Forward counter	
		2 = Reverse counter	
		3 = Net forward volume	
31	Pulse output C: unit of volume	00 = Litre (l)	
		01 = Cubic meter (m <sup>3</sup> ) (default)	
		02 = Gallon (gal)	
		03 = Imperial gallon (i.gal)	
		04 = Cubic feet (ft <sup>3</sup> )	
		05 = Acre feet (a-ft)	
		06 = Acre inch (a-in)	
		07 = Megalitre	
08 = Mega imperial gallon			
32	Pulse output C: pulse width	5 = 5 ms (default)	A small pulse width means a lower energy consumption of the battery.
		10 = 10 ms	
		20 = 20 ms	
		50 = 50 ms	
		100 = 100 ms	
		200 = 200 ms	
33	Pulse output C: pulse value	00100 = litre	Value to set in unit of volume per pulse. Unit and format are determined by setting menu item 31
		00.100 (default) = m <sup>3</sup> / pulse	
		0010.0 = gallon	
		0010.0 = imp. gallon	
		001.00 = ft <sup>3</sup>	
		.00100 = a-inch	
		.00100 = a-ft	
		.00100 = megalitre	
		.00100 = M.imp.gal.	
0.1000 = m <sup>3</sup> / pulse	When menu item A2 is set on 1		



## 6.3.7 Status output

No.	Function	Options	Description
40	Status output 1: Self check	0 = Off (default)	
		1 = On	
41	Status output 1: Battery pre notification	0 = Off (default)	Active in case of low battery (remaining capacity < 10%).
		1 = On	
42	Status output 1: Battery final notification	0 = Off (default)	Active in case of very low battery (remaining capacity < 1%).
		1 = On	
43	Status output 1: Empty pipe	0 = Off (default)	Active in case of empty pipe detection.
		1 = On	
44	Status output 1: P/T notification	0 (default)	Off
		1	Pressure limit max. [menu item 62]
		2	Pressure limit min. [menu item 63]
		3	Temperature limit max. [menu item 67]
		4	Temperature limit min. [menu item 68]
50	Status output 2: Self check	0 Off (default)	
		1 = On	
51	Status output 2: Battery pre notification	0 = Off (default)	Active in case of low battery (remaining capacity < 10%).
		1 = On	
52	Status output 2: Battery final notification	0 = Off (default)	Active in case of very low battery (remaining capacity < 1%).
		1 = On	
53	Status output 2: Empty pipe	0 = Off (default)	Active in case of empty pipe detection.
		1 = On	
54	Status output 2 P/T notification	0=[default]	Off
		1	Pressure limit max. [menu item 62]
		2	Pressure limit min. [menu item 63]
		3	Temperature limit max. [menu item 67]
		4	Temperature limit min. [menu item 68]

**WARNING!**

When setting the values of the temperature and / or pressure, the minimum value should not exceed the maximum value

### 6.3.8 Pressure and temperature settings

The following example of temperature warning setting, describes how to set the alarms (on upper or lower boundary) of the P&T sensor with the IFC 070.

- Tmax. = 25°C (menu number: 67)
- Tmin. = 7°C (menu number: 68)
- Tmax. limit (menu number 44, setting [3])
- Tmin. limit (menu number 54, setting [4])

Once the measured temperature reaches Tmax. (25°C), the status output 1 gives an alarm and sends out pulses. When the measured temperature decreases and reach Tmin. (7°C), the status output 2 gives an alarm (similar to status output 1). When the temperature stays within Tmax. - Tmin. limit settings, (7...25°C) no alarm will be set.

See the illustration below;

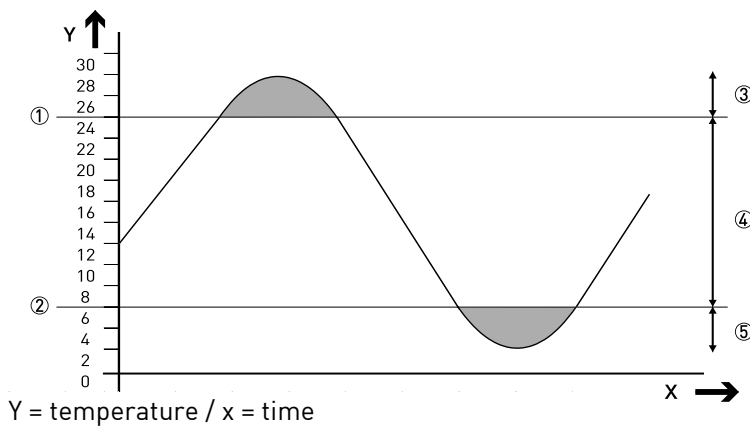

- ① Tmax
- ② Tmin
- ③ Status output 1; alarm
- ④ Status output 1 & 2; no alarm
- ⑤ Status output 2; alarm

## Pressure and temperature sensor settings

No.	Function	Options	Description
60	Pressure sensor	0= Off [default]	Disabled
		1 = On	Enabled
61	Pressure unit	00 [default]	bar (1 decimal)
		01	mbar (0 decimals)
		02	psi (0 decimals)
		03	mH <sub>2</sub> O (0 decimals)
62	Pressure limit, maximum	16.0	Range 0...16 bar (Default); xx.x
		16000	Range 0...16000 mbar; xxxxx
		232	Range 0...232 psi; xxx
		163	Range 0...163 mH <sub>2</sub> O; xxx
63	Pressure limit, minimum	-0.5	Range -0.5...16 bar; xx.x
		-0500	Range -500...16000 mbar; xxxxx
		-07	Range -7...232 psi; xxx
		-05	Range: -5...163 mH <sub>2</sub> O; xxx
64	Show pressure	0= Off [default]	Not visible in display
		1 = On	Visible in display
65	Temperature sensor	0= Off [default]	Disabled
		1 = On	Enabled
66	Temperature unit	00 [default]	°C
		01	°F
67	Temperature limit, maximum	070	Range 0...+70°C xxx
		158	Range 23...158°F xxx
68	Temperature limit, minimum	-05	Range -5...+70°C xxx
		23	Range 23...158°F xxx
69	Show temperature	0= Off	Not visible in display
		1 = On	Visible in display
70	P&T measuring interval	0	P&T measurement is the same as flow measurement. ①
		1	1 minute
		5	5 minutes
		10	10 minutes
		15 (default)	15 minutes

Pressure and temperature settings are optional for DN50...200 / 2...8"

① depending on measurement interval of menu setting 81

### 6.3.9 Measurement settings

By default the forward flow direction is set from left to right. The red arrow on the measurement flow sensor indicates the same direction. The flow direction can be set from right to left in menu number 80.

No.	Function	Options	Description
80	Flow direction	0 = Forward (default)	Sets the flow direction.
		1 = Reverse	
81	Measurement interval	5 = 5 sec	Sets the interval time between two measurements. The default value of 15 sec is chosen for an optimal energy consumption of the battery.
		10 = 10 sec	
		15 = 15 sec (default)	
		20 = 20 sec	
82	Low flow cut off	0 = 0 mm/s	Low flow cut off in mm/s. Measurements below this value are neglected.
		5 = 5 mm/s	
		10 = 10 mm/s (default)	
83	Empty pipe detection (EP)	0 = Off (default)	If switched to 1 (=on), the display shows "- EP -" in case of empty pipe and the measurement is stopped. In case of verification to MID Annex MI-001, the EP is set to on.
		1 = On	

### 6.3.10 Meter configuration settings



**INFORMATION!**

The meter constant (menu 92), zero offset calibration (menu 93) and zero selection (menu 94) are for service purposes only.

No.	Function	Options	Description
91	Meter size	Factory setting (xxx in mm)	By default the meter size is shown in mm. If menu nr. 10 (unit of volume for the counter) is set to 02, 03, 04, 05 or 06 the meter size is shown in inches. The meter size is also shown on the name plate and on the display.
92	Meter constant	Factory setting xx.xxx	The meter constant is also shown on the nameplate and on the display.
93	Zero offset calibration	0 = Off (default)	After a countdown the meter automatically switches back to the measuring mode and to the main display. The setting goes back to zero. Menu number 94 is automatically set to 1.
		1 = In situ determination of zero point	
94	Zero selection	0 = Factory setting (default)	Factory setting based on factory calibration
		1 = Measured value	The measured value is determined in situ if menu number 93 is set to 1.

### 6.3.11 Service and test settings



**WARNING!**

Activating a reset of all counters, means that previous values will be lost and cannot be re-covered.



**WARNING!**

Activating the verification mode affects the measurements and the counter value during the test procedure



**CAUTION!**

Menu number A0 Simulate outputs is for service purposes only.



**INFORMATION!**

Activation of add-on communication should be ordered with the meter. To use add-on communication for an existing installation please contact the service department.

No.	Function	Options	Description
A0	Simulate outputs	0 = Off	If set to 1 (= On) the pulse and status output automatically generate 1 pulse per second. Set back to 0 to stop the simulation.
		1 = On	
A1	Reset all counters	88888 = Off	Set to 00000 to reset all counters. The value of A1 will automatically switch back to 88888 after the reset.
		00000 = Reset	
A2	Verification mode	0 = Off	The display indicates Pxxxxxx, the decimal separator position varies per diameter. Please refer to <i>Verification mode</i> on page 64, for more details.
		1 = On	
A3	Add-on communication	0 = Off	Factory setting
		1 = On	

### 6.3.12 Battery settings

After changing the batteries:

- Reset the battery lifetime counter (Menu number B2)
- Select the battery type, if a different type of battery is used. (Menu number B0)
- Change the total battery capacity, if a different type of battery is used. (Menu number B1)

No.	Function	Options	Description
B0	Battery type	0 = No battery	A wrong setting influences the battery lifetime calculation.
		2 = Two internal batteries	
		3 = External battery pack	
		4 = FlexPower (2 battery)	
B1	Total battery capacity	xxx.xx = 019.00 (19.000 Ah)	Total of all batteries in Ah. After a change to a different battery type, change the setting (19 one battery, 38 two batteries, or 70 external battery)
B2	Reset battery lifetime counter	0 = Off	Set the value to 1 to reset the battery lifetime counter. After a reset, the menu setting automatically goes back to 0.
		1 = Reset	
B3	Modbus operating in case of power supply failure	0 = Off	Default = Off
		1 = On	

## 6.3.13 Modbus settings

**CAUTION!**

Changing the baudrate affects the battery lifetime.

For more details refer to the Modbus supplementary manual.

No.	Function	Options	Description
<b>Modbus RS485</b>			
C0	Modbus slave address	001	Value to be programmed (1 to 247)
C1	Baud rate	Baud rate choice from table:	
		1.2	1200 baud
		2.4	2400 baud
		3.6	3600 baud
		4.8	4800 baud
		9.6	9600 baud (default)
		19.2	19200 baud
		38.4	38400 baud
		57.6	57600 baud
115.2	115200 baud		
C2	Parity rate	0	Even (default)
		1	Odd
		2	No parity
C3	Register format	0	Little endian
		1	Big endian (default)
		2	Mix endian, small words
		3	Mix endian, large words
C4	Transmission delay	0 = 0ms	Transmission delay can be set by choice from table
		5 = 5ms	
		10 = 10ms	
		20 = 20ms	
		30 = 30ms	
		40 = 40ms	
		50 = 50ms (default)	
C5	Stop bits	1	1 Stop bit (default)
		2	2 Stop bits
C6	User application name	00000	To be set by programmer
C7	RS485 bus termination	0	No RS485 termination (default)
		1	RS485 termination 2 x 120 Ω
C8	Reception interval	0 (default)	Set value for range 0-3600 sec.

## 6.4 Tests

### 6.4.1 Automatic self-test

On a regular basis the WATERFLUX 3070 performs automatic self-tests. Tests done include an integrity check of the hardware and the software including a memory self-test, a calculation of the remaining battery lifetime, the battery current and checking of the coils current. If required, warnings and error messages as a result of the self-test are available on the display of the signal converter and optionally via the status outputs.

### 6.4.2 Verification mode



**WARNING!**

*Activating the verification mode, affects the measurement and the counter values during the test procedure.*

The WATERFLUX 3070 complies with the requirements of OIML R49 that the device shall provide means (i.e. display reading) for visual and unambiguous verification testing and calibration. In order to run a test, for example a comparison with a known volume, the meter can be set in a verification mode (menu number A2 should be set to 1).

In verification mode, menu settings are automatically adjusted in order to fulfil the requirements. First, the counters are shown with a modified number of decimals for a higher resolution on the display. The number of decimals depends on the size of the meter. The display indicates Pxxxxxx. Second, the measurement interval is automatically set to 1 measurement every 2 seconds. Third, the unit of volume is set to m<sup>3</sup>. To go back to the standard mode menu number A2 should be set to 0.

### 6.4.3 Test mode

A test mode is available, with which a second sum counter is activated. The second sum counter can be activated without breaking the metrological seals. Activating the second sum counter has no effect on the measurement and does not affect the counter values.

The second sum counter starts counting from 0. The resolution of the second sum counter is 100 times larger for a more detailed reading. If, for example, the counter shows 11m<sup>3</sup>, the second sum counter will indicate 11,xx m<sup>3</sup>. The maximum duration of the test is 3 hours. After 3 hours the meter will automatically return to its normal measuring mode.

Function	Keys	Display
To start the programming mode	Hold the ▼ and the ► key for 5 seconds	The display flashes
To enter the test mode	Press the ▼ key within 3 seconds	The display shows: - TEST - a second sum counter
To start the test (and to start the second counter)	Press the ▼ key	The test symbol starts to flash. The second counter starts at 0.
To reset the second counter	Press the ▼ key	The second counter starts at 0.
To stop the test / the second counter	Press the ► key	The TEST symbol stops flashing
To leave the test mode	Hold the ▼ and the ► key for 5 seconds	The display flashes.
	Press the ▼ key within 3 seconds	The second counter and the test symbol will disappear. The display returns to its normal measuring mode.



## 7.1 Types of batteries

Two types of batteries with different capacities are available. They can be exchanged by one of the other types.

As standard the IFC 070 signal converter is delivered with a lithium dual D cell (3.6V 38 Ah). Optionally, an external battery pack with a lithium dual DD cell (3.6V 70 Ah) can be connected.

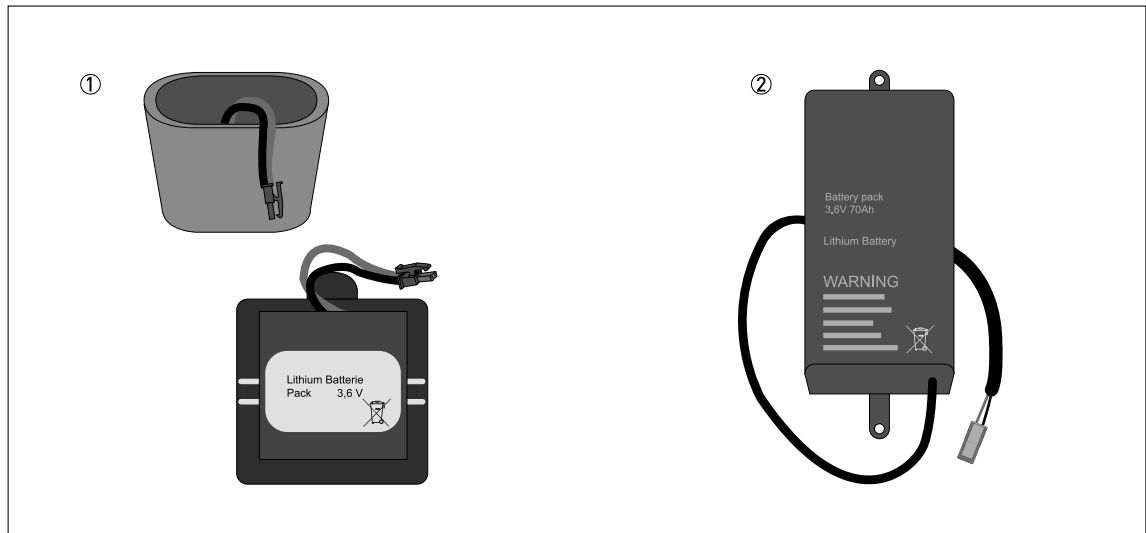

**Figure 7-1: Batteries and battery holders**

- ① Internal dual D-cell battery (without / in holder)
- ② External dual DD-cell KROHNE PowerBlock

### 7.1.1 Replacement of internal battery

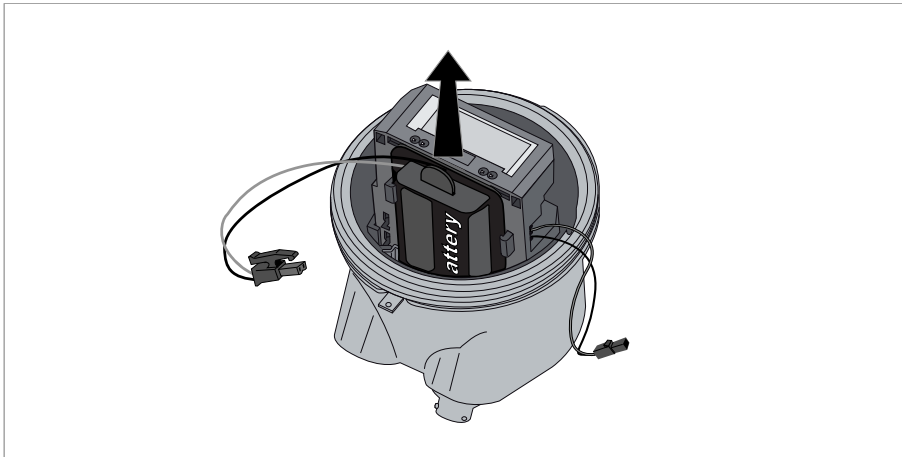

Figure 7-2: Removing the battery holder



- Loosen the locking ring with the special wrench.
- Remove the cover.
- Disconnect the connector of the battery.
- Remove the battery holder by pulling it upwards.
- Remove the battery from the holder.
- Insert the new battery in the holder.
- Replace the holder.
- Fasten the battery connector to the internal connector in the signal converter.
- Check if the display lights up.
- Put back the cover and locking ring. For closing the case of the device in the IP68 housing refer to *Closing of the signal converter housing* on page 26



**WARNING!**

*Make sure that the battery cable is not jammed by the cover.*



**INFORMATION!**

*After a change of batteries, reset the battery lifetime counter.  
For configuration of these menu settings refer to *Battery settings* on page 62.*

### 7.1.2 Replacement of external battery

In case of exchanging a battery (or power source) using an external battery already, this will be done on the side of the actual power source (battery) and not on the signal converter side.

When switching from an internal battery supply to an external battery supply

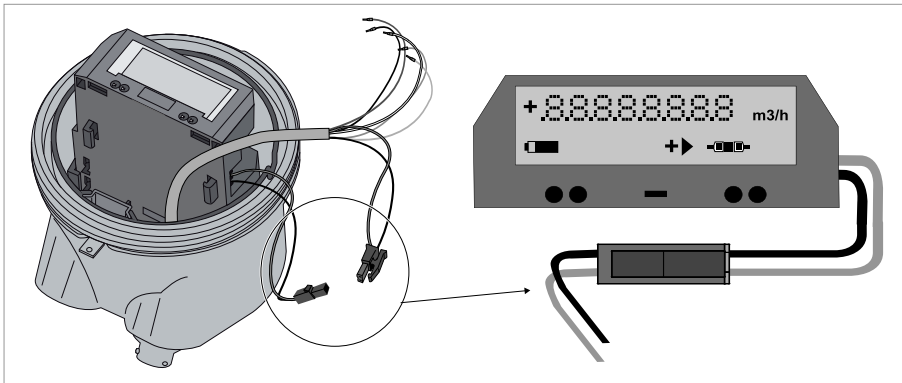

Figure 7-3: Connecting the external battery



- Loosen the locking ring with the special wrench
- Remove the cover.
- Disconnect the connector of the battery.
- Remove the old battery.
- Fasten the battery connector to the internal connector in the signal converter.
- Connect the external battery by the power connection cable and/or battery connection cable.
- Check if the display lights up.
- Put back the cover and lock, refer to *Closing of the signal converter housing* on page 26.



**WARNING!**

Make sure that the battery cable is not jammed by the cover.



**INFORMATION!**

After a change of batteries, reset the battery lifetime counter. For changing the menu settings of the battery refer to *Battery settings* on page 62.

## 7.2 Replacement of the KROHNE FlexPower unit

The WATERFLUX 3070 can be used with an (optional) external, main supply power pack which is suitable for pulse output or isolated Modbus.

The KROHNE FlexPower provides the necessary power supply for the IFC 070 signal converter.

An externally supplied voltage to the KROHNE FlexPower results in a 4.2 V DC output.

When a main power failure occurs, the internal dual D-cell battery will take over the power supply to the IFC 070 signal converter as back up, with a voltage of 3.6 V DC

For more information about battery lifetime refer to *Battery lifetime* on page 94

The input power for the KROHNE FlexPower can be realized by connecting:

- an AC mains supply source; range 110...230 VAC - 50/60 Hz  
or
- a DC supply source; range 10...30 VDC

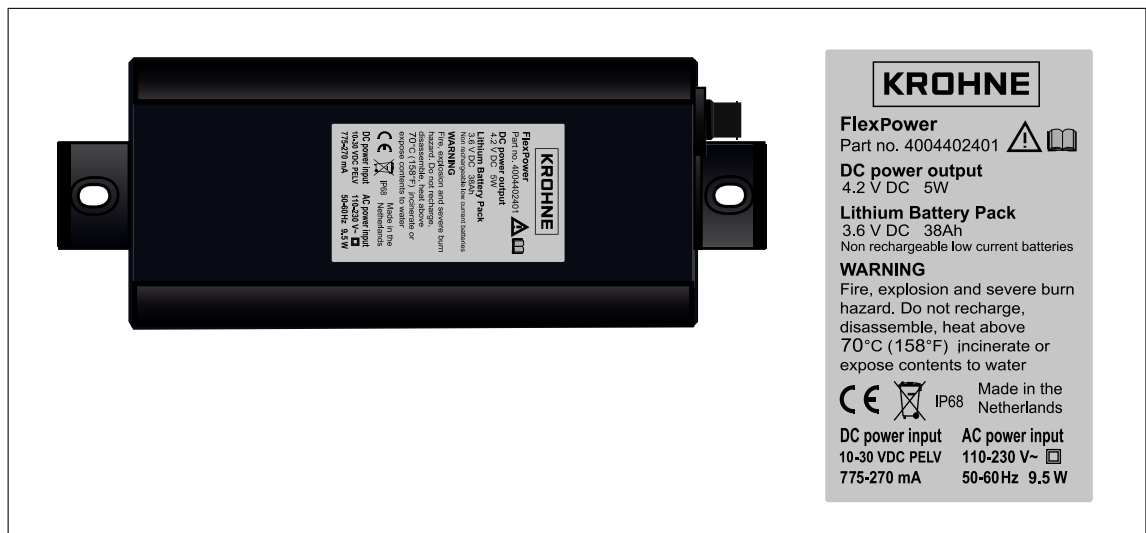

Figure 7-4: KROHNE FlexPower supply

Dimensions: L x W x H = 203 x 75 x 78 mm

\* The information in the illustration, can deviate from the actual marking!

## 7.3 Spare parts availability

The manufacturer adheres to the basic principle that functionally adequate spare parts for each device or each important accessory part will be kept available for a period of 3 years after delivery of the last production run for the device.

This regulation only applies to spare parts which are subject to wear and tear under normal operating conditions.

## 7.4 Availability of services

The manufacturer offers a range of services to support the customer after expiration of the warranty. These include repair, maintenance, technical support and training.



### **INFORMATION!**

*For more precise information, please contact your local sales office.*

## 7.5 Returning the device to the manufacturer

### 7.5.1 General information

This device has been carefully manufactured and tested. If installed and operated in accordance with these operating instructions, it will rarely present any problems.



### **WARNING!**

*Should you nevertheless need to return a device for inspection or repair, please pay strict attention to the following points:*

- *Due to statutory regulations on environmental protection and safeguarding the health and safety of the personnel, the manufacturer may only handle, test and repair returned devices that have been in contact with products without risk to personnel and environment.*
- *This means that the manufacturer can only service this device if it is accompanied by the following certificate (see next section) confirming that the device is safe to handle.*



### **WARNING!**

*If the device has been operated with toxic, caustic, radioactive, flammable or water-endangering products, you are kindly requested:*

- *to check and ensure, if necessary by rinsing or neutralising, that all cavities are free from such dangerous substances,*
- *to enclose a certificate with the device confirming that it is safe to handle and stating the product used.*

### 7.5.2 Form (for copying) to accompany a returned device



**CAUTION!**

*To avoid any risk for our service personnel, this form has to be accessible from outside of the packaging with the returned device.*

Company:		Address:	
Department:		Name:	
Telephone number:		Email address:	
Fax number:			
Manufacturer order number or serial number:			
The device has been operated with the following medium:			
This medium is:	<input type="checkbox"/>	radioactive	
	<input type="checkbox"/>	water-hazardous	
	<input type="checkbox"/>	toxic	
	<input type="checkbox"/>	caustic	
	<input type="checkbox"/>	flammable	
	<input type="checkbox"/>	We checked that all cavities in the device are free from such substances.	
	<input type="checkbox"/>	We have flushed out and neutralized all cavities in the device.	
We hereby confirm that there is no risk to persons or the environment caused by any residual media contained in this device when it is returned.			
Date:		Signature:	
Stamp:			

### 7.6 Disposal



**LEGAL NOTICE!**

*Disposal must be carried out in accordance with legislation applicable in your country.*

**Separate collection of WEEE (Waste Electrical and Electronic Equipment):**



According to the directive 2012/19/EU or UK Regulation 2013 No. 3113, the monitoring and control instruments marked with the WEEE symbol and reaching their end-of-life **must not be disposed of with other waste.**

The user must dispose of the WEEE to a designated collection point for the recycling of WEEE or send them back to our local organisation or authorised representative.

## 8.1 Measuring principle

An electrically conductive fluid flows inside an electrically insulated pipe through a magnetic field. This magnetic field is generated by a current, flowing through a pair of field coils.

Inside of the fluid, a voltage  $U$  is generated:

$$U = v * k * B * D$$

in which:

$v$  = mean flow velocity

$k$  = factor correcting for geometry

$B$  = magnetic field strength

$D$  = inner diameter of flowmeter

The signal voltage  $U$  is picked off by electrodes and is proportional to the mean flow velocity  $v$  and thus the flow rate  $Q$ . A signal converter is used to amplify the signal voltage, filter it and convert it into signals for totalizing, recording and output processing.

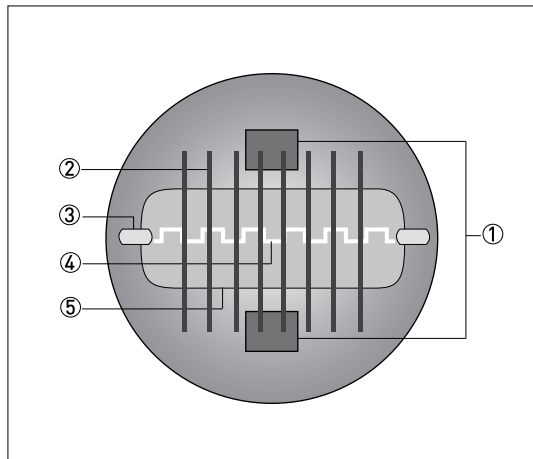

Figure 8-1: Measuring principle

- ① Field coils
- ② Magnetic field
- ③ Electrodes
- ④ Induced voltage (proportional to flow velocity)
- ⑤ Rectangular cross section

### Rectangular cross section

The minimal height of the measuring tube decreases the distance between the field coils (1), resulting in a stronger and more homogeneous magnetic field (2). In addition, the mean flow velocity  $v$  increases due to the rectangular and reduced cross section. The large electrode spacing ( $D$ ) and the increased flow velocity results in a higher magnetic signal voltage, also in the presence of a low flow rate.

## 8.2 Technical data



### INFORMATION!

- The following data is provided for general applications. If you require data that is more relevant to your specific application, please contact us or your local sales office.
- Additional information (certificates, special tools, software,...) and complete product documentation can be downloaded free of charge from the website (Downloadcenter).

### Measuring system

Measuring principle	Faraday's law of induction
Application range	Electrically conductive fluids
<b>Measured value</b>	
Primary measured value	Flow velocity
Secondary measured value	Volume flow
Optional measured value	Pressure and temperature

### Design

Features	Unique rectangular flow sensor design providing improved flow profile and signal to noise ratio resulting in highest accuracy, low energy consumption and large turndown ratio.
	Rilsan® polymer coated flow sensor approved for drinking water
	No internal or moving parts
	Built-in reference electrode
	Optional; built-in P&T sensor (restricted to DN50...200 / 1...8"), refer to <i>Integrated P&amp;T sensor (optional)</i> on page 79.
	Self-providing energy by batteries for up to 10 years
Modular construction	The measurement system consists of a flow sensor and a signal converter. It is available as a compact and as a remote version.
Compact version	With IFC 070 signal converter: WATERFLUX 3070 C
Remote version	In field (F) version with IFC 070 signal converter: WATERFLUX 3070 F
	Cable length up to 25 m / 70 ft, other lengths on request.
Nominal diameter	DN25...600 / 1...24", rectangular bore.



<b>Display and user interface</b>	
Display	LCD display, 8 digits.
Operation	2 Optical keys to navigate through the menu of the signal converter without opening the housing
Display information	<b>Standard:</b>
	Sum counter (default), forward counter, reverse counter or flow rate.
	Flow direction (forward or reverse), counter settings.
	Measured value and measuring unit
	Battery lifetime indicator
Optional:	Operating pressure, operating temperature, empty pipe, self-test, display test, test mode, diameter, meter constant, software version, AMR mode, notification sign, multiplier.
Remote reading	Optional: external GSM / GPRS data logger for pulse or Modbus For preselected data logger brands, please contact KROHNE.

### Measurements

Measuring units	<b>Volume</b>
	Default setting: m <sup>3</sup>
	Selectable: litre, gallon, imperial gallons, cubic feet, acre inch, acre feet, mega litre, mega imp. gallon.
	<b>Flow rate</b>
	Default setting: m <sup>3</sup> / hr
	Selectable: litre/sec, gallon/min, imperial gallon/min, cubic feet/hour, acre inch/day, acre feet/day, mega litre/day, mega imperial gallon/day.
Measurement interval	Default setting: 15s
Battery power	Selectable: 5s, 10s, 15s, 20s.
Measurement interval FlexPower	Default setting: 5s
Empty pipe detection	Optional: display shows - EP - in case of empty pipe detection
Low flow cut off	Measurements below this value are neglected
	Default setting: 10 mm/s
	Selectable: 0 mm/s, 5 mm/s, 10 mm/s

## Measuring accuracy

Maximum measuring error	DN25...300 / 1...12"; down to 0.2% of the measured value $\pm 1$ mm/s DN350...600 / 14...24"; down to 0.4% of the measured value $\pm 1$ mm/s
	The maximum measuring error depends on the installation conditions
	For detailed information refer to <i>Measurement accuracy</i> on page 88.
Repeatability	DN25...300 / 1...12"; $\pm 0.1\%$ ( $v > 0.5$ m/s / 1.5 ft/s) DN350...600 / 14...24"; $\pm 0.2\%$ ( $v > 0.5$ m/s / 1.5 ft/s)
Calibration / Verification	<b>Standard:</b> 2 Point calibration by a direct volume comparison
	<b>Optional:</b> for DN25...600 / 1...24"
	Verification to Measurement Instrument Directive (MID) Annex III (MI-001) Standard: Verification at Ratio (Q3/Q1) = 80 Optional: Verification at Ratio (Q3/Q1) > 80
MID Annex III (MI-001) (Directive 2014/32/EU / UK Regulation 2016 No. 1153)	<b>EC-Type examination certificate to MID Annex III (MI-001)</b>
	Diameter: DN25...600 / 1...24"
	Minimum straight inlet flow: 0 DN
	Minimum straight outlet flow: 0 DN
	Forward and reverse (bi-directional) flow
	Orientation: any
	Ratio (Q3/Q1): up to 630
	Liquid temperature range: +0.1...50°C / +32...122°F
	Maximum operating pressure: $\leq$ DN200 / 8": 16 bar / 232 psi, $\geq$ DN250 / 10": 10 bar / 150 psi.
	For detailed information refer to <i>Legal metrology</i> on page 82.
OIML R49	<b>Certificate of conformity to OIML R49 (edition 2006)</b>
	Diameter: DN25...600 / 1...24"
	Accuracy: Class 1 and 2
	Minimum straight inlet flow: 0 DN
	Minimum straight outlet flow: 0 DN
	Forward and reverse (bi-directional) flow
	Orientation: any
	Ratio (Q3/Q1): up to 400
	Liquid temperature range: +0.1...50°C / +32...122°F
	Maximum operating pressure: $\leq$ DN200 / 8": 16 bar / 232 psi, $\geq$ DN250 / 10": 10 bar / 150 psi.
For detailed information refer to <i>Legal metrology</i> on page 82.	

### Operating conditions

<b>Temperature</b>	
Process temperature	-5...+70°C / +23...+158°F
Ambient temperature	-25...+65°C / -13...+149°F
	Ambient temperatures below -25°C / -13°F may affect the readability of the display
	It is recommended to protect the signal converter from external heat sources such as direct sunlight, because high temperatures reduce the life cycle of all electronic components and the battery.
Storage temperature	-30...+70°C / -22...+158°F
<b>Measurement range</b>	
Starting flow	From 0 m/s / 0 ft/s onwards
<b>Pressure</b>	
Operating pressure	Up to 16 bar (232 psi) for DN25...200 / 1...8" Up to 10 bar (150 psi) for DN250...600 / 10...24"
Vacuum load	0 mbar / 0 psi absolute
Pressure loss	For detailed information refer to <i>Pressure loss</i> on page 93.
<b>Chemical properties</b>	
Physical conditions	Water: drinking water, raw water, irrigation water. For salt water, please contact the factory.
Electrical conductivity	≥ 20 µS/cm

### Installation conditions

Installation	Assure that flow sensor is always fully filled.
	For detailed information refer to <i>Installation</i> on page 15.
Flow direction	Forward and reverse
	Arrow on flow sensor indicates forward flow direction
Inlet run	≥ 0 DN
	For detailed information refer to <i>Measurement accuracy</i> on page 88.
Outlet run	≥ 0 DN
	For detailed information refer to <i>Measurement accuracy</i> on page 88.
Dimensions and weights	For detailed information refer to <i>Dimensions and weights</i> on page 90.

## Materials

Sensor housing	Sheet steel
Measuring tube	DN25...200 / 1...8": metallic alloy
	DN250...600 / 10...24": stainless steel
Flanges	DN25...150 / 1...6": Stainless steel 1.4404 / 316L DN200 / 8": Stainless steel 1.4301 / 304L DN250...DN600 / 10...24": steel St37-C22 / A105 Optional: DN250...600 / 10...24": Stainless steel
Liner	Rilsan®
Protective coating	On exterior of the meter: flanges, housing and / or connection box (field version).
	Standard: coating
	Option: subsoil coating
Measuring electrodes	Standard: stainless steel 1.4301 / AISI 304
	Optional: Hastelloy® C
Reference electrode	Standard: stainless steel 1.4301 / AISI 304
	Optional: Hastelloy® C
Grounding rings	Grounding rings can be omitted when the reference electrode is used
Signal converter housing	Polycarbonate
Wall holder for remote signal converter	Polycarbonate
Connection box	Only for remote versions.
	Stainless steel

## Process connections

EN 1092-1	<b>Standard:</b>
	DN25...200 / 1...8": PN 16
	DN250...600 / 10...24": PN 10
	<b>Optional:</b>
	DN250...600 / 10...24": PN 16 (DN350...600: 10 bar rated)
ASME B16.5	1...8": 150 lb RF (232 psi / 16 bar rated) 10...24": 150 lb (150 psi / 10 bar rated)
JIS B2220	DN25...300 / 1...12": 10 K DN350...600 / 14"...24": 7,5 K
AS 4087	DN25...600 / 1"...24": Class 16 on request (DN350...600 / 14"...24": 10 bar rated)
AS 2129	DN25...600 / 1"...24": Table D, E on request (DN350...600 / 14"...24": 10 bar rated)
For detailed information on nominal flange pressure and nominal diameter refer to <i>Dimensions and weights</i> on page 90.	

Other connections	
Thread	DN25: G1" thread connection
	DN40: G1½ " thread connection
Other	Weld-on, clamp, oval flanges: on request.

### Electrical connections

Cable connections		
Cable entries	Compact and field version: <b>IFC 070 C and F</b>	
	Connection with 1 or 2 snap-on connectors	
Output cable	<b>IFC 070 compact and field version</b>	
	Standard: Pulse- or Modbus output cable	
	Optional: Pulse output activated and connection to the KGA 42 data logger - GPRS module. Output cable with 2 plug and play - IP68 rated connectors	
Power supply		
Battery	<b>Standard:</b>	
	Internal battery pack: Dual D-cell (Lithium, 3.6V, 38 Ah).	
	<b>Optional:</b>	
	External IP67 PowerBlock: Dual DD-cell (Lithium, 3.6V, 70 Ah). Cable length is 1.5 meter / 5 feet	
KROHNE FlexPower <b>Optional:</b>	External IP68 rated AC/DC power supply (110...230V AC ± 10% / 10...30 V DC / 50-60Hz) with battery backup Dual D-cell (Lithium, 3.6V, 38 Ah). Cable length is 1.5 meter / 5 feet	
Typical lifetime (default settings)	With 2 internal batteries;	DN25...200 / 1...8": up to 10 years DN250...600 / 10...24": up to 7 years
	With external KROHNE PowerBlock;	DN25...200 / 1...8": up to 16 years DN250...600 / 10...24": up to 13 years
	For detailed information refer to <i>Battery lifetime</i> on page 94	
Notifications	Pre-notification at < 10% of its original capacity	
	Final notification at < 1% of its original capacity	
Battery replacement	No loss of totalizer data	

<b>Sensor cable</b> (remote versions only)	
Type	KROHNE WSC2 standard cable, double shielded.
Length	Standard: 5 meter / 16 feet
	Optional: 10 meter / 33 feet, 25 meter / 82 feet.
	Other cable lengths on request (max. 30 meter)
<b>In- and output</b>	
Pulse output	2 Passive pulse outputs (maximum 3 outputs possible; see status output). $f \leq 100$ Hz; $I \leq 10$ mA; $U: 2.7...24$ VDC ( $P \leq 100$ mW).
	Volume / pulse is programmable
	Phase shift between pulse A and B (forward and reverse) selectable
	Pulse width is selectable: 5 ms (default), 10 ms, 20 ms, 50 ms, 100 ms, 200 ms.
Status output	2 Passive status outputs (1 status output can be used as a third pulse output)
	$I \leq 10$ mA; $U: 2.7...24$ VDC ( $P \leq 100$ mW)
	Function (selectable): pressure limit maximum, pressure limit minimum, temperature limit maximum, temperature limit minimum, self-check, battery pre notification, battery final notification, empty pipe.
Communication	Internal & external batteries: Passive pulses or non-galvanic separated Modbus KROHNE FlexPower: Passive pulses or galvanic separated Modbus

### Approvals and certificates

<b>CE</b>	
This device fulfills the statutory requirements of the relevant directives. The manufacturer certifies successful testing of the product by applying the conformity mark on the device.	
	For more information on the directives, standards and the approved certifications, please refer to the declaration of conformity supplied with the device or downloadable from the manufacturer's website.
Custody transfer  Not valid for integrated temperature and pressure sensor	Directive: 2014/32/EU / UK Regulation 2016 No. 1153 MID Annex III (MI-001) type examination certificate (DN25...600 / 1...24")
	OIML R49 edition 2006 certificate of conformity (DN25...600 / 1...24")
	Innerstaatliche Bauartzulassung als Kaeltezaehler (For Germany, Switzerland and Austria)
	NMI M10 Certificate of approval for accuracy class 2.5 (Australia)
	DN40...100; SANS 1529 (South Africa)
	Contact Product Support KROHNE
<b>Other approvals and standards</b>	
Drinking water approvals	ACS, DVGW W270, NSF / ANSI Standard 61, UBA, WRAS, KIWA
Protection category according to IEC 60529	Compact (C) and field (F) version in polycarbonate housing: IP68, NEMA 4X/6P and IP68 FlexPower unit / IP67 External battery pack (Test conditions; 1500 hours, 10 meters / 33 feet below surface)
Shock test	IEC 60068-2-27
	30 g for 18 ms
Vibration test	IEC 60068-2-64
	$f = 20...2000$ Hz, rms = 4.5g, t = 30 min.

### 8.3 Integrated P&T sensor (optional)

#### Design

Features	Optional: integrated pressure and temperature sensor in the WATERFLUX 3000 flow sensor.
	In combination with: IFC 070 (compact and remote) WATERFLUX 3000 flow sensor DN50...200 / 2...8"

#### Measurements

Measuring range	Pressure
	-0.5...16 bar / -7.3...232 psi (relative)
	Temperature
	-5...+70°C / +23...158°F
Measuring units	
Pressure	Default setting: bar
	Selectable: mbar, psi
Temperature	Default setting: °C
	Selectable: °F
Measurement interval	Default setting: 15 min.
	Selectable: 1 min., 5 min., 10 min., 15 min. or equal to the measurement flow interval.

#### Measuring accuracy

Maximum measuring accuracy	Pressure
	± 1% of full scale (0.5...16 bar / -7.3...232 psi)
	Temperature
	± 1.5°C for -5°...+70°C / +23...158°F

#### Materials

Pressure and temperature sensor	316L
---------------------------------	------

## 8.4 KROHNE FlexPower (optional)

**Design**

Features	The WATERFLUX 3070 can be connected to an external FlexPower unit. The input power for the FlexPower can be realized by connection to a AC/DC supply source
	Protection class; IP68
	Housing material; polypropylene

**Operating range**

Input	110...230 V AC $\pm$ 10%, 50-60 Hz, 9.5W
	10...30 V DC, 775-230 mA
Output	4.2 V DC, 5W
Cable (Output)	Combined power and output (Y-cable) with snap-on connector
Power Cable	DC cable (green) and AC cable (grey)
Temperature	
Storage and transport temperature	-30...+70°C / -22...158°F
Maximum operating temperature	-25...+65°C / -13...149°F

**Approval**

Transport	Certificate under UN38.3 requirements (Transportation Tests for Lithium batteries)
<b>Other approval and standards</b>	
Protection category according to IEC 60529	KROHNE FlexPower: IP68, NEMA 4X/6P (Test conditions; 1500 hours, 10 meters / 33 feet below surface)
Shock test	IEC 60068-2-27
	30 g for 18 ms
Vibration test	IEC 60068-2-64
	f = 20...20000 Hz, rms = 4.5g, t = 30 min.



## 8.5 Modbus protocol (option)

The Modbus option on the WATERFLUX 3070 is available in two versions:

- not isolated (battery powered) - for standard internal battery version
- galvanically isolated (mains powered) - for KROHNE FlexPower version

The WATERFLUX 3070 flow converter and FlexPower with Modbus has a RS485 interface to communicate with an external device (PC or other suitable computer system) using the Modbus protocol. This option allows data exchange between PC or computer and single or multiple devices. The bus configuration consists of one external device as a master and one or more signal converters as slaves.

For bus operation, the device address, parity, baud rate, stop bits, data format and transmission delay must be set in the signal converter. All devices connected to the bus, must have the same baud rate and settings, but different (unique) addresses.



### CAUTION!

*Please note that changing the baud rate will greatly affect the units battery life time. The baud rate equal to and below 9600 bps are considered energy efficient while baud rates greater than 9600 bps are not.*



### CAUTION!

*Do not use a bus termination for the non-isolated standard battery powered version (will effect the lifetime)!*

### General technical data

Baud rate	1200, 2400, 3600, 4800, 9600 (default), 19200, 38400, 57600 or 115200
Protocol	Modbus RTU (documentation available on the Modbus Organisation website)
Data encoding	All Modbus data fields are encoded according to the IEC 61131-3 standard
Maximum participants on bus	32 per line, master included (may be extended by repeaters)
Coding	NRZ bit coding
Address range	Modbus: 1...247
Transmission procedure	Half duplex, asynchronous
Bus access	Master / slave
Device role	Slave
Cable	Shielded twisted pair for RS 485 applications
Distances	Isolated: Maximum 1.2 km / 3937 ft without repeater (dependent on baud rate and cable specifications) multi-drop
	Non-isolated: Maximum 100 m, without termination (point to point)



### INFORMATION!

*For more details refer to the Modbus supplementary manual.*

## 8.6 Legal metrology

### 8.6.1 OIML R49

The WATERFLUX 3070 has a certificate of conformity with the international recommendation OIML R49-1. The certificate has been issued by NMI (Dutch board of weight and measures).

The OIML R49 -1 concerns water meters intended for the metering of cold potable and hot water. The measuring range of the water meter is determined by Q3 (nominal flow rate) and R (ratio).

The WATERFLUX 3070 meets the requirements for water meters of accuracy class 1 and 2.

- For accuracy class 1, the maximum permissible error for water meters is  $\pm 1\%$  for the upper flow rate zone and  $\pm 3\%$  for the lower flow rate zones.
- For accuracy class 2, the maximum permissible error for water meters is  $\pm 2\%$  for the upper flow rate zone and  $\pm 5\%$  for the lower flow rate zones.

According to OIML R49, accuracy class 1 designation shall be applied only to water meter with  $Q3 \geq 100 \text{ m}^3/\text{h}$ .

Refer to the technical datasheet of WATERFLUX 3070 for further details of the certification.

$$Q1 = Q3 / R$$

$$Q2 = Q1 * 1.6$$

$$Q3 = Q1 * R$$

$$Q4 = Q3 * 1.25$$



Figure 8-2: ISO flow rates added to figure as comparison towards OIML

**X:** Flow rate

**Y [%]:** Maximum measuring error

①  $\pm 3\%$  for class 1,  $\pm 5\%$  for class 2 devices

②  $\pm 1\%$  for class 1,  $\pm 2\%$  for class 2 devices

## OIML R49 Class 1; certified metrological flow characteristics

DN	Span (R) Q3 / Q1	Flow rate [m <sup>3</sup> /h]			
		Minimum Q1	Transitional Q2	Permanent Q3	Overload Q4
50	400	0.10	0.16	40	50
65	250	0.400	0.64	100	125
80	250	0.640	1.02	160	200
100	250	1.00	1.60	250	312.5
125	250	1.60	2.56	400	500
150	250	2.52	4.03	630	787.5
200	160	3.9375	6.30	630	787.5
250	160	6.25	10.00	1000	1250
300	160	10.00	16.00	1600	2000
350	160	15.625	25.00	2500	3125
400	160	25	40.00	4000	5000
450	160	25	40.00	4000	5000
500	160	39.375	63.00	6300	7875
600	100	63	100.80	6300	7875

## OIML R49 Class 2; certified metrological flow characteristics

DN	Span (R) Q3/Q1	Flow rate [m <sup>3</sup> /h]			
		Minimum Q1	Transitional Q2	Permanent Q3	Overload Q4
25	400	0.025	0.040	10	12.5
25	400	0.040	0.064	16	20.0
40	400	0.0625	0.100	25	31.3
40	400	0.100	0.160	40	50.0
50	400	0.100	0.160	40	50.0
50	400	0.1575	0.252	63	78.75
65	400	0.1575	0.25	63	78.75
65	400	0.250	0.40	100	125.0
80	400	0.250	0.40	100	125.0
80	400	0.400	0.64	160	200.0
100	400	0.400	0.64	160	200.0
100	400	0.625	1.00	250	312.5
125	400	0.625	1.00	250	312.5
125	400	1.000	1.60	400	500.0
150	400	1.000	1.60	400	500.0
150	400	1.575	2.52	630	787.5
200	400	1.575	2.52	630	787.5
250	400	2.500	4.00	1000	1250
300	400	4.000	6.40	1600	2000
350	160	15.625	25.0	2500	3125
400	160	25.000	40.0	4000	5000
450	160	25.000	40.0	4000	5000
500	160	39.375	63.00	6300	7875
600	160	63.000	100.80	6300	7875

### 8.6.2 MID Annex III (MI-001)

All new designs of water meters that are to be used for legal purposes in Europe require certification under the Measurement Instrument Directive (MID) 2014/32/EU / UK Regulation 2016 No. 1153 Annex III (MI-001).

Annex MI-001 of the MID applies to water meters intended for the measurement of volume of clean, cold or heated water in residential, commercial and light industrial use. An EC-type examination certificate is valid in all countries of the European Union.

The WATERFLUX 3070 has a type examination certificate and can be verified to the MID Annex III (MI-001) for water meters with diameter DN25...DN600.

The conformity assessment procedure followed for WATERFLUX 3070 is Module B (Type Examination) and Module D (Quality Assurance of the Production Process).

- The maximum permissible error on volumes delivered between Q2 (transitional) flow rate and Q4 (overload) flow rate is  $\pm 2\%$ .
- The maximum permissible error on volumes delivered between Q1 (minimum) flow rate and Q2 (transitional) flow rate is  $\pm 5\%$ .

Refer to the technical datasheet of the WATERFLUX 3070 for further details of the certification.

$$Q1 = Q3 / R$$

$$Q2 = Q1 * 1.6$$

$$Q3 = Q1 * R$$

$$Q4 = Q3 * 1.25$$

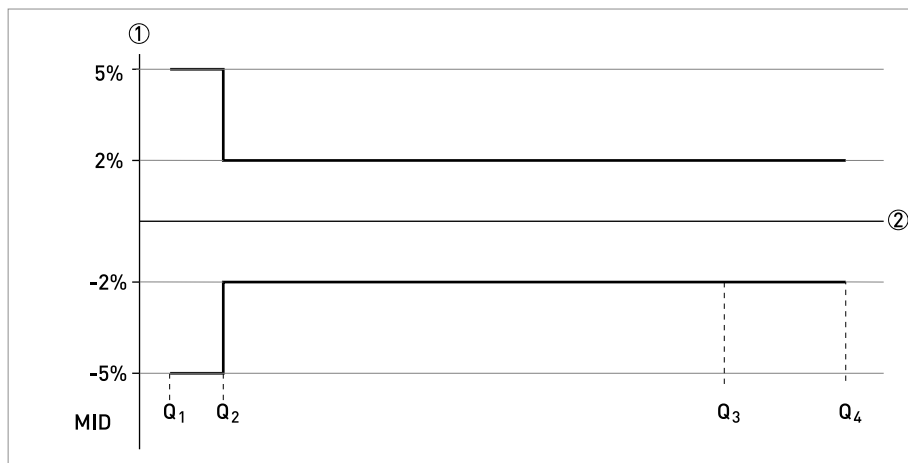

Figure 8-3: ISO flow rates added to figure as comparison towards MID

X: Flow rate

Y [%]: Maximum measuring error

## MI-001 certified flow characteristics

DN	Span (R) Q3 / Q1	Flow rate [m <sup>3</sup> /h]			
		Minimum Q1	Transitional Q2	Permanent Q3	Overload Q4
25	640	0.025	0.040	16	20.0
40	640	0.0625	0.100	40	50.0
50	630	0.100	0.160	63	78.75
65	635	0.1575	0.252	100	125.0
80	640	0.25	0.400	160	200.0
100	625	0.40	0.640	250	312.5
125	640	0.625	1.00	400	500.0
150	630	1.00	1.60	630	787.5
200	508	1.575	2.52	630	787.5
250	400	2.50	4.00	1000	1250
300	400	4.00	6.40	1600	2000
350	160	15.625	25.0	2500	3125
400	160	25.00	40.0	4000	5000
450	160	25.00	40.0	4000	5000
500	160	39.375	63.0	6300	7875
600	100	63.00	100.8	6300	7875

## 8.6.3 Verification to MID Annex III (MI-001) and OIML R49

**INFORMATION!**

Verification at other values for R and Q3 or to OIML R49 class 1 is available on request.

## Verification to MID Annex III (MI-001)

DN	Span (R)	Flow rate [m <sup>3</sup> /h]		
		Q1	Q2	Q3
25	80	0.050	0.08	4
40	80	0.125	0.20	10
50	80	0.200	0.32	16
65	80	0.313	0.50	25
80	80	0.500	0.80	40
100	80	0.788	1.26	63
125	80	1.250	2.00	100
150	80	2.000	3.20	160
200	80	3.125	5.00	250
250	80	5.000	8.00	400
300	80	7.875	12.60	630
350	80	20.00	32.0	1600
400	80	31.25	50.0	2500
450	80	31.25	50.0	2500
500	80	50.00	80.0	4000
600	80	78.75	126	6300

## 8.7 Measurement accuracy

Every electromagnetic flowmeter is calibrated by direct volume comparison. The wet calibration validates the performance of the flowmeter under reference conditions against accuracy limits.

The accuracy limits of electromagnetic flowmeters are typically the result of the combined effect of linearity, zero point stability and calibration uncertainty.

### Reference conditions

- Medium: water
- Temperature: +5...+35°C / +41...+95°F
- Operating pressure: 0.1...5 barg / 1.5...72.5 psig
- Inlet section:  $\geq 3$  DN
- Outlet section:  $\geq 1$  DN

Note: the performance of the water meter is defined and documented in an individual water meter calibration certificate.

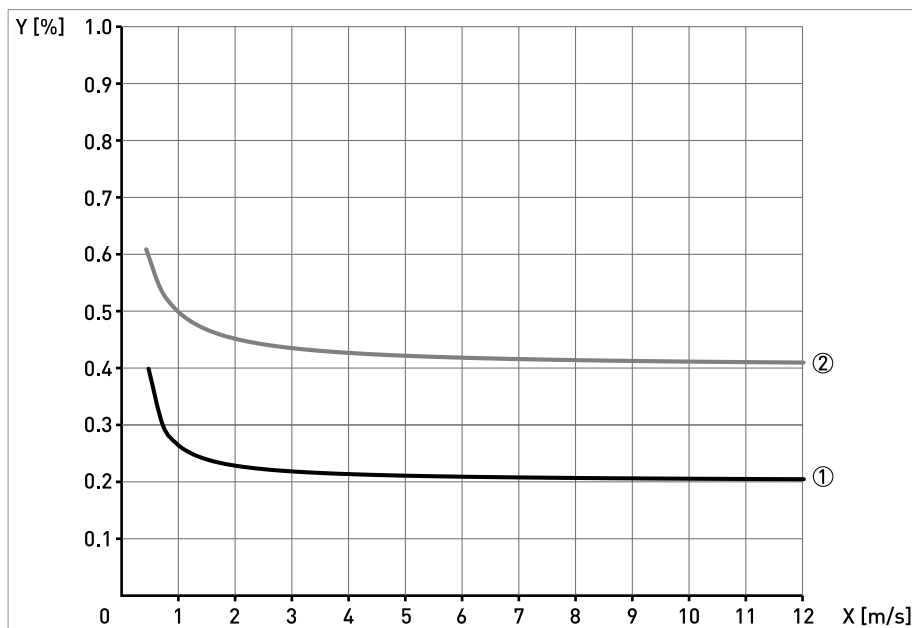

Figure 8-4: Measuring accuracy  
X [m/s]: Flow velocity; Y [%]: Maximum measuring error

### Accuracy with signal converter IFC 070

Size	Accuracy	Curve
DN25...300 / 1...12"	0.2% of the measured value $\pm$ 1 mm/s	①
DN350...600 / 14...24"	0.4% of the measured value $\pm$ 1 mm/s	②



### 8.7.1 WATERFLUX 3070 without straight inlet and outlet sections

Disturbed flow profiles, such as those that occur behind elbows, tee pieces, reducers or valves installed in front of a water meter, affect the measuring performance. Therefore it is usually recommended to fit a straight inlet length in front of and straight outlet length behind a water meter.

As a result of the unique WATERFLUX 3000 flow sensor design, whereby the mean flow velocity and flow profile are optimized within the rectangular and reduced cross section, the additional uncertainty for upstream disturbances are drastically reduced. Therefore the requirements for straight length and in front of and behind a meter are reduced.

The NMI has performed tests with various flow and swirl disturbers according to ISO 4064 and EN 14154. Based on these results the WATERFLUX 3070 has received the following certificates:

#### **OIML R49 certificate**

- In combination with the signal converter IFC 070
- Diameter range DN25...600 / 1...24"
- Accuracy class 1 and class 2
- Minimum straight inlet and outlet pipe length of 0 DN
- Bi-directional flow

#### **Type certificate according MID Annex III (MI-001)**

- In combination with the signal converter IFC 300
- Diameter range DN25...600 / 1...24"
- Minimum straight inlet and outlet pipe length of 0 DN
- Bi-directional flow

8.8 Dimensions and weights

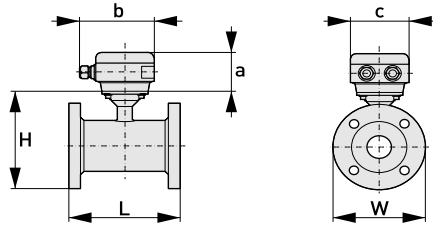
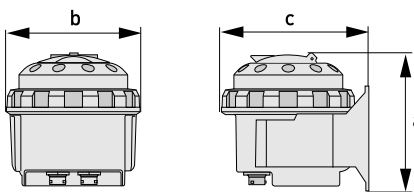
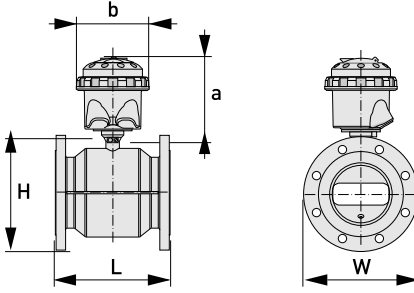
<p>Remote flow sensor</p>		<p>a = 88 mm / 3.5"</p> <p>b = 139 mm / 5.5" ①</p> <p>c = 106 mm / 4.2"</p> <p>Total height = H + a</p>
<p>Remote signal converter in polycarbonate housing (IP68)</p>		<p>a = 171 mm / 6.7"</p> <p>b = 161 mm / 6.3"</p> <p>c = 177 mm / 7"</p>
<p>Compact version in polycarbonate housing (IP68)</p>		<p>a = 159 mm / 6.3"</p> <p>b = 161 mm / 6.3"</p> <p>Total height = H + a</p>

① The value may vary depending on the used cable glands.

**INFORMATION!**

- All data given in the following tables are based on standard versions of the flow sensor only.
- Especially for smaller nominal sizes of the flow sensor, the signal converter can be bigger than the flow sensor.
- Note that for other pressure ratings than mentioned, the dimensions may be different.
- For full information on signal converter dimensions see relevant documentation.

**EN 1092-1**

Nominal size DN [mm]	Dimensions [mm]			Approx. weight [kg]
	L	H	W	
25	150	151	115	5
40	150	166	150	6
50	200	186	165	13
65	200	200	185	11
80	200	209	200	17
100	250	237	220	17
125	250	266	250	21
150	300	300	285	29
200	350	361	340	36
250	400	408	395	50
300	500	458	445	60
350	500	510	505	85
400	600	568	565	110
450	600	618	615	125
500	600	671	670	120
600	600	781	780	180

## ASME B16.5 / 150 lb

Nominal size [inch]	Dimensions [inch]			Approx. weight [lb]
	L	H	W	
1	5.91	5.83	4.3	18
1½	5.91	6	4.9	21
2	7.87	7.05	5.9	34
3	7.87	8.03	7.5	42
4	9.84	9.49	9.0	56
5	9.84	10.55	10.0	65
6	11.81	11.69	11.0	80
8	13.78	14.25	13.5	100
10	15.75	16.3	16.0	148
12	19.7	18.8	19.0	210
14	27.6	20.7	21	290
16	31.5	22.9	23.5	370
18	31.5	24.7	25	420
20	31.5	27	27.5	500
24	31.5	31.4	32	680

### 8.9 Pressure loss

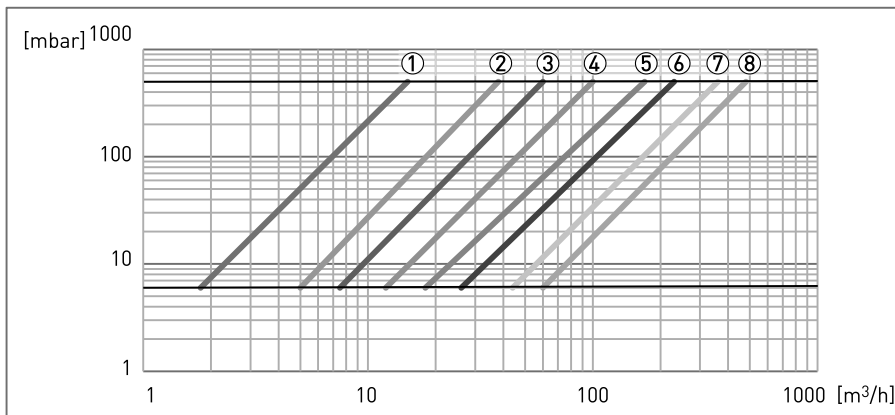

Figure 8-5: Pressure loss between 1...9 m/s / 3.3...30 ft/s for DN25...150 / 1...6"

- ① DN25 / 1"
- ② DN40 / 1½"
- ③ DN50 / 2"
- ④ DN65 / 2½"
- ⑤ DN80 / 3"
- ⑥ DN100 / 4"
- ⑦ DN125 / 5"
- ⑧ DN150 / 6"

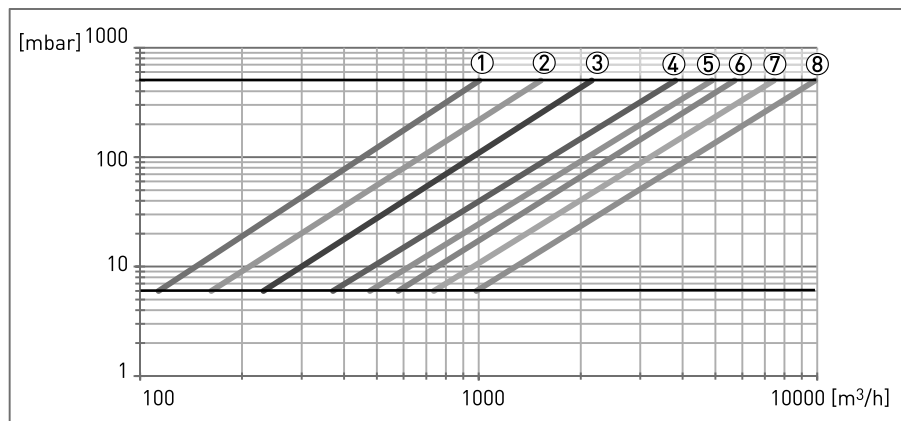

Figure 8-6: Pressure loss between 1...9 m/s / 3.3...30 ft/s for DN200...600 / 8...24"

- ① DN200 / 8"
- ② DN250 / 10"
- ③ DN300 / 12"
- ④ DN350 / 14"
- ⑤ DN400 / 16"
- ⑥ DN450 / 18"
- ⑦ DN500 / 20"
- ⑧ DN600 / 24"

### 8.10 Battery lifetime

The maximum battery lifetime depends on the choice of battery pack, the diameter and on the measurement interval. Other factors influencing the battery lifetime include the ambient temperature, the pulse output settings, the status output, the pulse width and the Modbus baud rate settings. The graphs show the battery lifetime for the different available battery types and measurement intervals.

#### Conditions

The maximum battery lifetime is based on default menu and Modbus settings, an ambient temperature of 25°C / 77°F and a flow rate at 2 m/s. The effect of the optional pressure and temperature sensor decreases the battery lifetime by 5% (on average).

#### Maximum lifetime of batteries for: DN25...200 / 1...8"

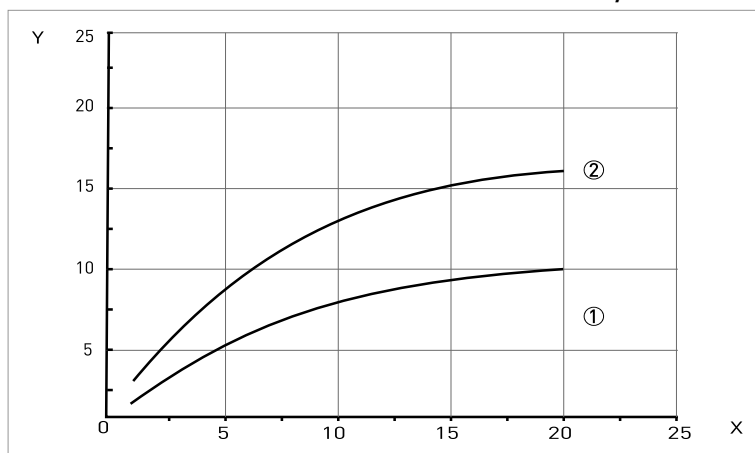

Figure 8-7: X = Measuring interval in seconds, Y = typical lifetime in years

#### Maximum lifetime of batteries for: DN250...600 / 10...24"

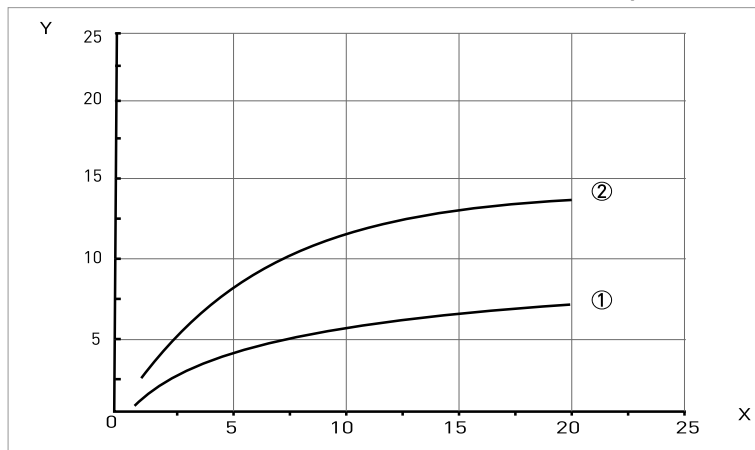
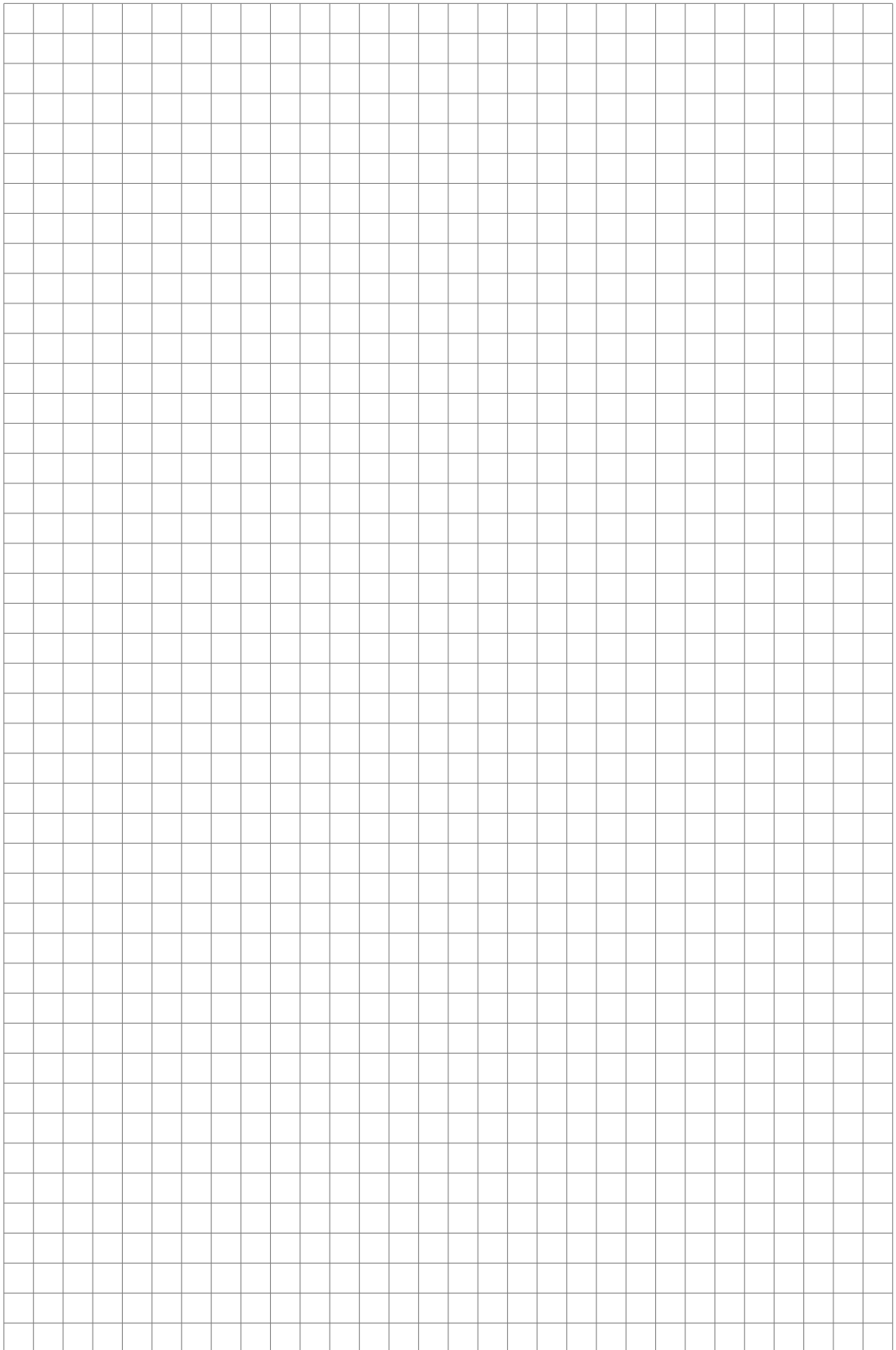

Figure 8-8: X = Measuring interval in seconds, Y = typical lifetime in years

- ① Internal Dual D-cell battery
- ② External KROHNE PowerBlock



## **KROHNE – Products, Solutions and Services**

- Process instrumentation for flow, level, temperature, pressure measurement and process analytics
- Flow metering, monitoring, wireless and remote metering solutions
- Engineering, commissioning, calibration, maintenance and training services

Head Office KROHNE Messtechnik GmbH  
Ludwig-Krohne-Str. 5  
47058 Duisburg (Germany)  
Tel.: +49 203 301 0  
Fax: +49 203 301 10389  
info@krohne.de

The current list of all KROHNE contacts and addresses can be found at:  
[www.krohne.com](http://www.krohne.com)

**KROHNE**